

## GigE uEye®RE



IP 65/67

Your imagination is our challenge

# GigE uEye® RE

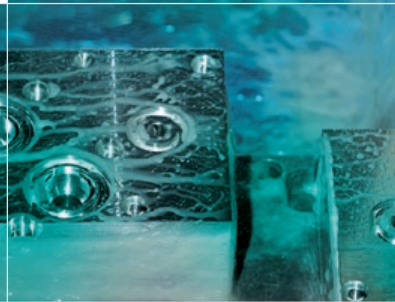

Lockable I/O and GigE connectors



Wide variety of filters

Very rugged housing

M3 and M5 mounting threads for flexible mounting

Complies with protection class IP 65/67 in combination with optional accessories



Accessories for drag chains

Accessories for harsh environments  
Protection class IP 65/67

## GigE uEye® RE – the camera for almost anywhere

The RE versions of the GigE uEye cameras are extremely rugged and offer an extended area of application. In conjunction with the special lens tubes and appropriate cabling, they meet the requirements of protection classes IP 65 and IP 67. The GigE uEye RE is thus particularly suited for harsh environments.

## Firmware upload philosophy

The modular uEye concept can also be found in our software: All necessary drivers are only loaded into the camera after it has been connected. With regularly released updates the functionality can thus be enhanced even for already installed cameras.

	Resolution	Framerate	Sensor	Shutter	B/W	Color	Model
<b>up to 1 Megapixel</b>							
VGA	640 x 480	75 fps	1/3" SONY CCD	global	x	x	UI-6410RE
VGA	640 x 480	75 fps	1/2" SONY CCD	global	x	x	UI-6210RE
WVGA	752 x 480	100 fps	1/3" Aptina CMOS	<b>global</b>	x	x	UI-5220RE
CCIR / PAL	768 x 576	52 fps	1/2" SONY CCD	global	x	x	UI-6220RE
XGA	1024 x 768	30 fps	1/3" SONY CCD	global	x	x	UI-6230RE
<b>1 to 2 Megapixel</b>							
1,3 MPixel	1280 x 1024	50 fps	1/1.8" E2V CMOS	<b>global</b>		x	UI-5240RE
1,3 MPixel	1280 x 1024	35 fps	1/2" Aptina CMOS	rolling	x		UI-5540RE
1,3 MPixel	1280 x 1024	25 fps	1/3" Aptina CMOS	rolling		x	UI-5640RE
1,3 Mpixel	1280 x 960	28 fps	1/3" SONY CCD	global	x		UI-6140RE
1,3 Mpixel	1280 x 1024	15 fps	1/2" SONY CCD	global	x	x	UI-6240RE
2 MPixel	1600 x 1200	23 fps	1/3" Aptina CMOS	rolling		x	UI-5550RE
2 MPixel	1600 x 1200	12 fps	1/2" SONY CCD	global	x	x	UI-6250RE
<b>over 2 Megapixel</b>							
3,1 MPixel	2048 x 1536	15 fps	1/2" Aptina CMOS	rolling		x	UI-5460RE
5 MPixel	2448 x 2050	8 fps	2/3" SONY CCD	global	x	x	UI-6280RE
5 Mpixel	2560 x 1920	14 fps	1/2" Aptina CMOS	rolling; global start	x	x	UI-5480RE
10 MPixel	3840 x 2748	6 fps	1/2" Aptina CMOS	rolling	x	x	UI-5490RE
<b>High Dynamic Range (HDR)</b>							
CCIR / PAL	768 x 576	50 fps	1/1.8" HDR CMOS	rolling	x		UI-5120RE

## Very Easy Integration Thanks to Comprehensive Software

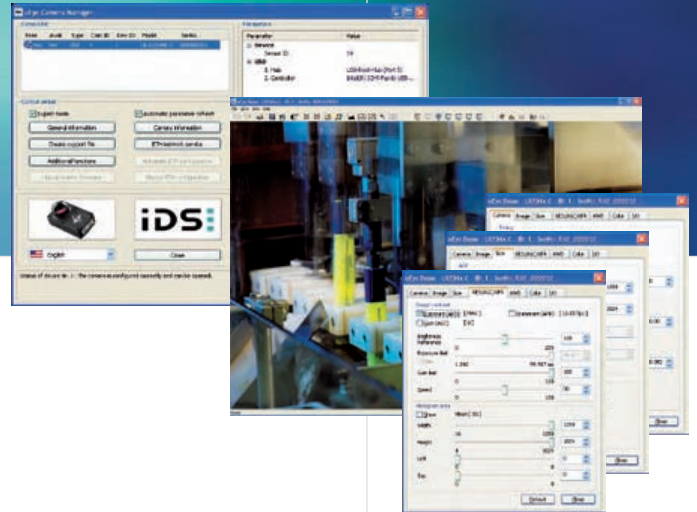

### Programming: SDK and interfaces

With every uEye camera, you receive a comprehensive software package with drivers for Windows and Linux. Interfaces for various image processing packages, standard drivers such as DirectShow (WDM), a GenICam™ interface as well as our Software Development Kit (SDK) allow individual integration within a very short time.

### Programming: Languages and libraries

To make integration as easy as possible and allow use of your familiar development environment, we support the following programming languages: C, C++, C#, Microsoft .NET and Visual Basic. We also provide 3rd party software drivers for Activision Tools, Common Vision Blox, HALCON, LabView, and NeuroCheck.

### Tools: Easy configuration

The uEye Camera Manager is the central tool for managing all uEye connected to the system. An expert mode gives you additional details on the connected cameras. This central tool helps you avoid bottlenecks and achieve maximum performance.

### Tools: uEye® Demo

The supplied uEye demo program allows you to start acquiring images with your uEye camera in no time at all. It also allows you to perform image measurement and annotation, in addition to giving you all the tools to configure optimal camera settings for your application.

## The uEye® Software

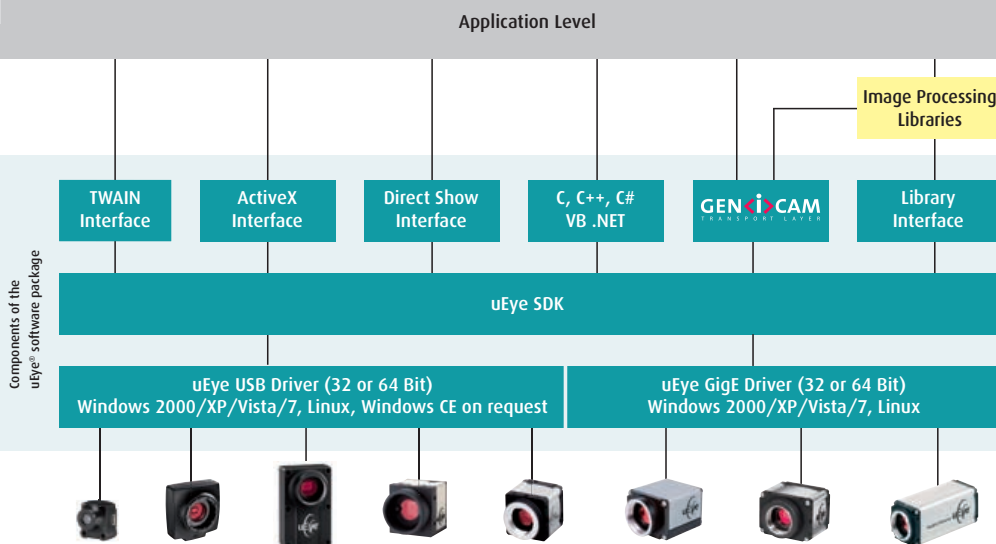



## Ultra High Dynamic Range with the uEye® HDR Sensor

Based on a logarithmic curve, the 1/1.8" HDR CMOS sensor can capture images with an ultra high dynamic range of 120 dB without overexposure – that's 1,000 times more than the dynamic range of a conventional sensor. As the cameras of the GigE uEye series can transfer 12-bit color depth, you can use the full dynamic range of the sensor for your machine vision applications. The low-noise sensor with PAL resolution (768 x 576 pixels) captures up to 50 frames/sec.

### Image capture in strong backlighting

Conventional sensors have difficulties in dealing with strong backlight conditions. The resulting images are often very dark, making people and faces difficult to see in the image. With the HDR sensor, a scene will be clearly visible even where areas are underexposed.

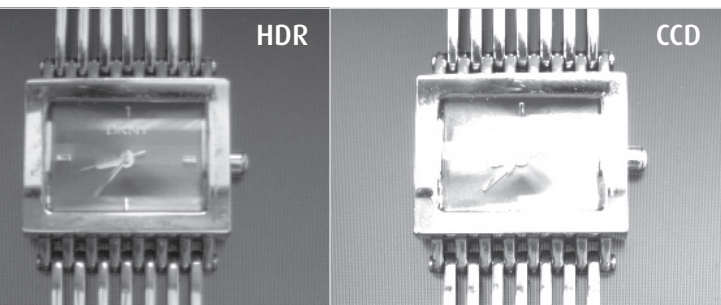
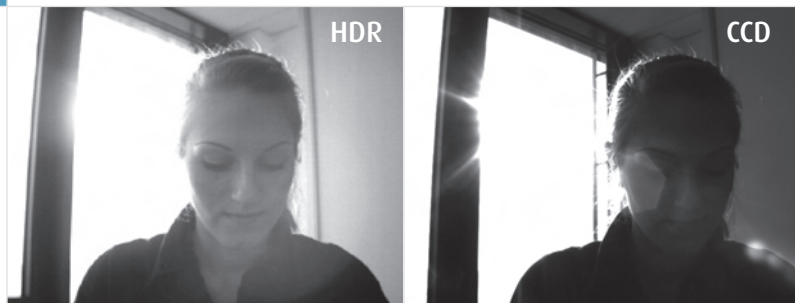

### Image capture of reflective surfaces

Reflective surfaces such as glass, metal or paint can cause glare on important areas of the image. The image data is lost in those areas. uEye HDR cameras allow you to analyze details even in very bright areas of an image.

### Image capture in interfering light

In factory buildings, you often cannot avoid unwanted glare on the object from interfering light sources, such as sunlight. In situations like these, the dynamic range of the HDR CMOS sensor gives you sufficient scope to achieve optimum image quality all the same.

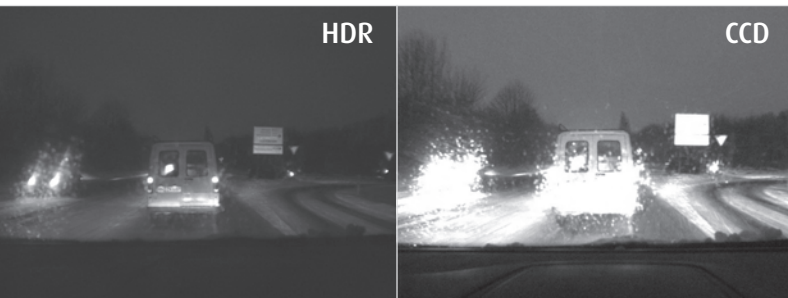
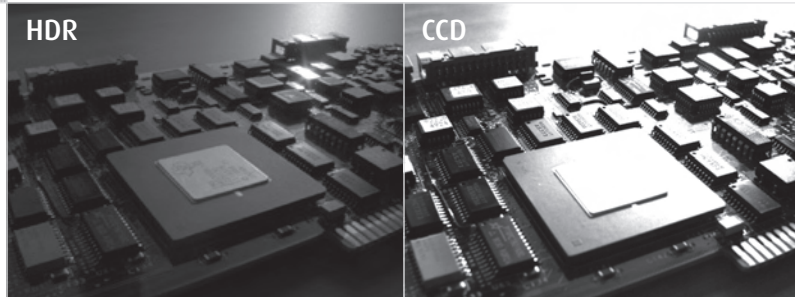

### Image capture under rapidly changing light conditions

Where lighting conditions can change very quickly and unforeseeably, the HDR CMOS sensor is far superior to conventional sensors. It ensures in traffic surveillance systems, for example, that license plates can be identified even in the glare of oncoming headlights without over-lighting areas of the image.

### Key features at a glance

- Complies with protection class IP 65/67 in combination with optional accessories
- Lockable GigE and I/O connectors
- Universal use with PC, notebook, IPC and embedded systems with Gigabit Ethernet
- Resolutions from VGA (640x480) to 10 Megapixel (3840 x 2748)
- High-quality CCD and CMOS sensors
- Up to 100 full frames/sec., over 500 frames/sec. with AOI
- Digital input, opto-isolated, can be used for triggering
- Digital output, opto-isolated, can be used for flash control
- Single driver for all uEye cameras
- 3rd party drivers for most common image processing software applications, including LabView, HALCON, Common Vision Blox and NeuroCheck
- On-the-fly firmware upload approach ensures camera is always up to date
- GenICam™ interface

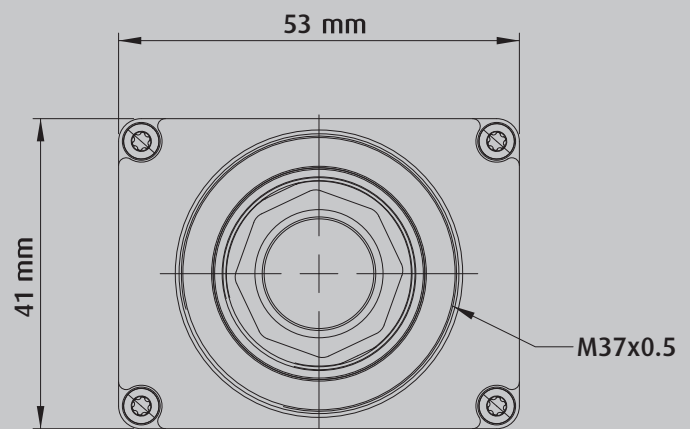
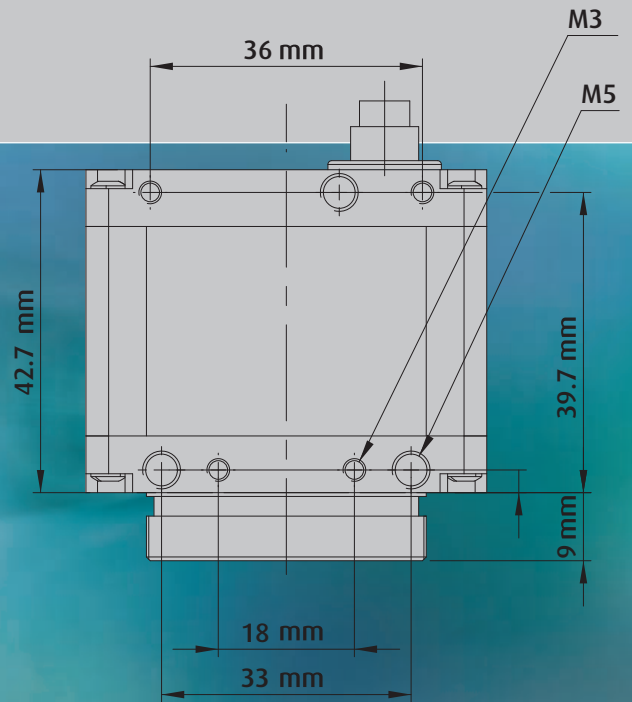

Scale 1:1 (GigE uEye RE CMOS) – 3D CAD data on request

