



CCD Color Camera
FireDragon Color series
CSFV90CC3
CSFX36CC3
CSFS20CC2
CSFU15CC18
Specifications

Contents

CASES FOR INDEMNITY (LIMITED WARRANTY)

RESTRICTION FOR USE

Notes on using this product

1. Overview.....	1
2. Features.....	1
3. Configuration.....	2
4. Optional part.....	2
5. Functions.....	3
6. Specifications.....	6
7. Timing chart.....	16
8. Outline Drawing.....	26

TOSHIBA TELI CORPORATION

Printed on recycled paper

D4147243A

CASES FOR INDEMNITY (LIMITED WARRANTY)

We shall be exempted from taking responsibility and held harmless for damage or losses incurred by the user in the following cases.

- In the case damage or losses are caused by fire, earthquake, or other acts of God, acts by a third party, deliberate or accidental misuse by the user, or use under extreme operating conditions.
- In the case of indirect, additional, consequential damages (loss of business interests, suspension of business activities) are incurred as result of malfunction or non-function of the equipment, we shall be exempted from responsibility for such damages.
- In the case damage or losses are caused by failure to observe the information contained in the instructions in this instruction manual and specifications.
- In the case damage or losses are caused by use contrary to the instructions in this instruction manual and specifications.
- In the case damage or losses are caused by malfunction or other problems resulting from use of equipment or software that is not specified.
- In the case damage or losses are caused by repair or modification conducted by the customer or any unauthorized third party (such as an unauthorized service representative).
- Expenses we bear on this product shall be limited to the individual price of the product.

RESTRICTION FOR USE

- Should the equipment be used in the following conditions or environments, give consideration to safety measures and inform us of such usage:
 1. Use of the equipment in the conditions or environment contrary to those specified, or use outdoors.
 2. Use of the equipment in applications expected to cause potential hazard to people or property, which require special safety measures to be adopted.
- This product can be used under diverse operating conditions. Determination of applicability of equipment or devices concerned shall be determined after analysis or testing as necessary by the designer of such equipment or devices, or personnel related to the specifications. Such designer or personnel shall assure the performance and safety of the equipment or devices.
- This product is not designed or manufactured to be used for control of equipment directly concerned with human life (*1) or equipment relating to maintenance of public services/functions involving factors of safety (*2). Therefore, the product shall not be used for such applications.
 - (*1): Equipment directly concerned with human life refers to.
 - Medical equipment such as life-support systems, equipment for operating theaters.
 - Exhaust control equipment for exhaust gases such as toxic fumes or smoke.
 - Equipment mandatory to be installed by various laws and regulations such as the Fire Act or Building Standard Law
 - Equipment related to the above
 - (*2): Equipment relating to maintenance of public services/functions involving factors of safety refers to.
 - Traffic control systems for air transportation, railways, roads, or marine transportation
 - Equipment for nuclear power generation
 - Equipment related to the above

Notes on using this product

- **Handle carefully**

Do not drop the equipment or allow it to be subject to strong impact or vibration, as such action may cause malfunctions. Further, do not damage the connection cable, since this may cause wire breakage.

- **Environmental operating conditions**

Do not use the product in locations where the ambient temperature or humidity exceeds the specifications. Otherwise, image quality may be degraded or internal components may be adversely affected. In particular, do not use the product in areas exposed to direct sunlight. Moreover, during shooting under high temperatures, vertical stripes or white spots (noise) may be produced, depending on the subject or camera conditions (such as increased gain). However, such phenomena are not malfunctions.

- **Check a combination with the lens**

Depending on the lens and lighting you use, an image is reflected as a ghost in the imaging area. However, this is not because of a fault of the camera.

In addition, depending on the lens you use, the performance of the camera may not be brought out fully due to deterioration in resolution and brightness in the peripheral area, aberration and others.

Be sure to check a combination with the camera by using the lens and lightning you actually use.

When installing a lens in the camera, make sure carefully that it is not tilted.

In addition, use a mounting screw free from defects and dirt. Otherwise, the camera may be unable to be removed.

- **Do not shoot under intense light**

Avoid intense light such as spot lights on part of the screen because it may cause blooming or smears. If intense light falls on the screen, vertical stripes may appear on the screen, but this is not a malfunction.

- **Occurrence of moiré**

If you shoot thin stripe patterns, moiré patterns (interference fringes) may appear. This is not a malfunction.

- **Occurrence of noise on the screen**

If an intense magnetic or electromagnetic field is generated near the camera or connection cable, noise may be generated on the screen. If this occurs, move the camera or the cable.

- **Handling of the protective cap**

If the camera is not in use, attach the lens cap to the camera to protect the image pickup surface.

- **If the equipment is not to be used for a long duration**

Turn off power to the camera for safety.

- **Maintenance**

Turn off power to the equipment and wipe it with a dry cloth.

If it becomes severely contaminated, gently wipe the affected areas with a soft cloth dampened with diluted neutral detergent. Never use alcohol, benzene, thinner, or other chemicals because such chemicals may damage or discolor the paint and indications.

If the image pickup surface becomes dusty, contaminated, or scratched, consult your sales representative.

- **Disposal**

When disposing of the camera, it may be necessary to disassemble it into separate parts, in accordance with the laws and regulations of your country and/or municipality concerning environmental contamination.

1. Overview

This FireDragon Color series is an integrated-(one-body)-type color camera that adopts all pixel data readout inter line CCD. There are 4 models according to the sensor type. These are CSFV90CC3 (VGA), CSFX36CC3 (XGA), CSFS20CC2 (SXGA), and CSFU15CC18 (UXGA). For video output, the serial digital bus standard “IEEE1394.b” is adopted for high transfer rate, and it is easy to integrate into industrial equipment.

2. Features

- **High frame rate and high resolution**

Supported high frame rate CSFV90CC3 (90fps/VGA), CSFX36CC3 (36fps/XGA), CSFS20CC2 (20fps/SXGA), and CSFU15CC18 (15fps/UXGA).

- **All pixel readout**

All pixel signals (in the effective area) are output in one frame processing.

- **Full frame shutter**

Since all pixels are output even by shutter operation, high resolution can be achieved, without deteriorating the vertical resolution.

- **Square grids**

The CCD pixels arrayed in square grids facilitates computation for image processing.

- **Color processing**

Since color processing is built in, there are also RGB (24bit), YUV 4:2:2 (16bit), YUV 4:1:1 (12bit) output modes besides Raw output mode (8/10bit).

- **IEEE1394 interface**

Performs video output and camera control via the signal digital bus standard IEEE1394.b interface.

Data transfer is at 800Mbps that can output video data of high frame rate.

It is bilingual standard.

- **Random trigger shutter**

The random trigger shutter function provides images in any timing by input of an external trigger signal.

Trigger control from PC is possible.

- **Scalable**

Selectable video output area. It can be higher frame rate by reducing vertical output area. And can be reduce occupied data rate of IEEE1394 by reducing horizontal output area.

- **High-speed draft readout mode**

By thinning out vertical lines, it can be read all effective area at high-speed frame rate.

- **Compact and lightweight**

This camera is compact and lightweight, and it is easy to integrate into industrial equipment.

- **RoHS compliant**

3. Configuration

- (1) Camera body 1
 - (2) Accessories
 - Instruction Manual (Japanese)..... 1
 - Instruction Manual (English)..... 1
- *No application software is attached to this camera.

4. Optional part

- (1) Camera mounting kit Model name: CPT1100CL
- *Contact your dealer / distributor for details of option units.

5. Functions

(1) Setup-level setting

By adjusting the setting value of the command status register of the camera via the IEEE1394 serial bus, you can set the Setup-level in 192 steps in the range between 6.3 and 25%.

(2) Gain setting

There is AGC (Auto Gain Control) other than manual setting, too. Setting range and effective range are 0 to +6dB.

(3) White balance

There are two types of white balancing mode, MWB (Manual White Balance) and OPWB (One Push White Balance). You can set white balancing mode, according to the subject and purpose.

(4) Gamma correction

You can set gamma correction ON/OFF.

* The user cannot adjust the correction amount.

(5) Masking correction

The hue of images is masking corrected so that it will be natural (ON fixed).

* The user cannot adjust the correction amount.

(6) High-speed draft readout mode

By thinning out vertical lines, it can be read all effective area at high-speed frame rate.

* As for CSFV90CC3 (VGA), this mode supports a fault.

	CSFV90CC3	CSFX36CC3	CSFS20CC2	CSFU15CC18
Draft mode		1/3	1/2	1/4
Readout vertical line		254	480	300
maximum frame rate		86 fps	34fps	46fps

(7) Electronic shutter mode switching

You can switch the shutter modes by adjusting the setting value of the command status register of the camera via the IEEE1394 serial bus. The setting method has three kinds of the following.

- AE (Auto Exposure)

The brightness is adjusted automatically by the average photometry of the entire screen.

- Effective range 1/20000s to OFF
- Effective area Full screen
- Exposure level -1EV to +1EV (1/3EV step)

By combining this mode and AGC (ALC mode), it can follow so much to brightness change of subject.

- Normal shutter

Performs exposure control via the internal synchronization signal.

- PRESET setting 1/100s, 1/250s, 1/500s, 1/1000s, 1/2000s, 1/4000, 1/10000, and 1/20000s
(set up in the Value field of CSR register)
- Absolute value setting Any value is set up in 32-bit floating point form within the range of 1/20000s to 2s
(set up in the Absolute Value Control of CSR register)

- Random trigger shutter

Random trigger shutter can capture images at any timing using the external trigger signal and soft trigger input.

It is effective for image input of moving objects and obtaining images of the same timing using multiple cameras. But there is an exposure delay time.

The random trigger shutter of this camera can be operated in two types of mode. How to determine the exposure time differs depending on the mode.

- Fixed mode The exposure time depends on the normal shutter speed setting.
- Pulse width mode The exposure time depends on the pulse width.

Notes on fixed mode of Random trigger shutter:

- It is outside a guarantee when having set it as this mode, and a normal shutter is turned off. Please be sure to turn on a normal shutter.

Notes on long exposure:

- When you set the exposure time longer than approximately 1 second, white spots and the unevenness in highlight portion might occasionally be observed on screen. This phenomenon is due to the characteristics of the CCD image-pickup device, and do not reflect performance error in the pickup device or CCD Camera itself.

(8) Scalable mode

This camera has the scalable mode that can read out defined area of the screen. Only continuous rectangle units can be selected, concave or convex shape cannot be selected.

- Window size: $\{A * m(H)\} * \{B * n(V)\}$

A and B are minimum unit size.

m, n=integer

The image of maximum unit size or less can be selected.

Only one window can be selected.

	CSFV90CC3	CSFX36CC3	CSFS20CC2	CSFU15CC18
Minimum unit size (H) * (V)	160 * 120	256 * 192	160 * 120	200 * 150
Maximum unit size (H) * (V)	640 * 480	1024 * 768	1280 * 960	1600 * 1200

- Start address: $\{32 * i(H)\} * \{24 * j(V)\}$

i, j=integer

The image of maximum unit size or less can be selected.

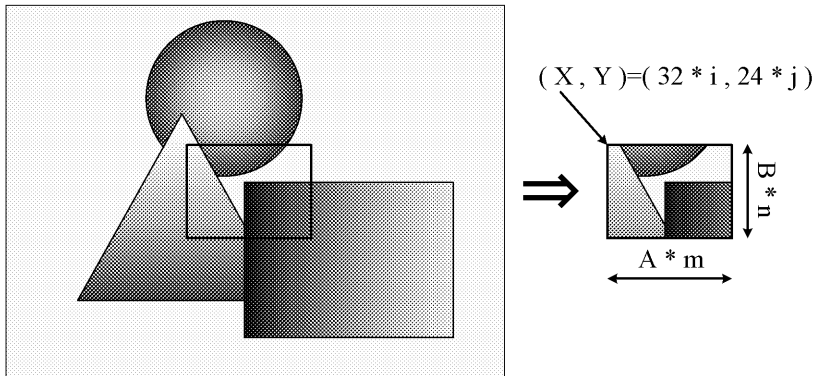

In the scalable mode, this camera reads out only the necessary portions at the standard speed while it scans through other unnecessary portions at high speed, so the trigger interval can be shorter if the vertical cutout width is small. However, the trigger interval cannot be short in the horizontal direction even if the cutout width is small due to the operation mechanism of the CCD sensor.

Notes on scalable mode:

- White lines may occur in the upper portions of the screen when strong light exists in a wide area during the scalable mode. This is not a malfunction. If white lines occur, adjust the amount of incident light using the lens.

6. Specifications

[Electrical specification]

- (1) Imager all-pixel-data-readout interline transfer CCD

	CSFV90CC3	CSFX36CC3	CSFS20CC2	CSFU15CC18
Number of total pixels (H) * (V)	692*504	1077*788	1434*1050	1688*1248
Number of effective pixels (H) * (V)	659*494	1034*779	1392*1040	1628*1236
Number of Video out pixels (H) * (V)	640*480	1024*768	1280*960	1600*1200
Scanning area (H) * (V)	4.88mm*3.66mm (1/3 type)	4.81mm*3.62mm (1/3 type)	6.47mm*4.84mm (1/2 type)	7.16mm*5.44mm (1/1.8 type)
Pixel size (H) * (V)	7.4μm*7.4μm	4.65μm*4.65μm	4.65μm*4.65μm	4.40μm*4.40μm
Color filter	RGB primary color mosaic-on-tip color filter			

- (2) Scan method Non-interrace
 (3) Synchronization method Internal synchronization
 (4) Aspect ratio 4:3
 (5) Sensitivity

	CSFV90CC3	CSFX36CC3	CSFS20CC2	CSFU15CC18
Standard subject illuminance	1700 lx F5.6 5000K	2400 lx F5.6 5000K	1400 lx F5.6 5000K	1000 lx F8 5000K

- (6) Minimum subject illuminance (F1.4, GAIN Maximum, video level 50 %, Gamma ON)

	CSFV90CC3	CSFX36CC3	CSFS20CC2	CSFU15CC18
Minimum subject illuminance	20 lx	27 lx	18 lx	7 lx

- (7) Gain AGC/Manual switching (initial factory setting :Manual)
 -AGC (Auto Gain Control)
 •Effective range 0 to +6dB
 •Effective area Full screen
 * When the random shutter is active, AGC function is disabled.
 * When Raw output mode (8/10bit), AGC function is disabled.
 -Manual setting
 •Setting range 0 to +6 dB (46 step, initial factory setting : 0 dB)

- (8) Gamma correction ON/OFF switching (initial factory setting :ON)
 * When Raw output mode(8/10bit), Gamma correction function is disabled (OFF fixed).
- (9) Masking correction ON fixed
 * When Raw output mode(8/10bit), Masking correction function is disabled (OFF fixed).
- (10) White balance OPWB/MWB switching (initial factory setting: MWB)
 -OPWB (One Push White Balance)
 •Effective range 2500 K to 6500 K
 •Effective area Full screen
 * When the random shutter is active, OPWB function is disabled.
 * When Raw output mode (8/10bit), OPWB function is disabled.
 -MWB (Manual White Balance)
 •Setting range 2500 K to 6500 K
 •Setting method R-gain and B-gain can be set independently.
 * When Raw output mode (8/10bit), MWB setting is disabled.
- (11) Setup-level
 •Setting range 6.3 to 25 %
 (192step, initial factory setting : 6.3% [Approximately 16digit/8bit])
 * When Raw output mode (8/10bit), Setup-level setting is disabled.
- (12) Power supply DC +8 to +30 V (ripple 100 mV(p-p) or less)
- (13) Power consumption 2.6 W (Maximum)

[Internal sync signal specification]

- (1) Base clock frequency 36.0000 MHz +/- 100ppm

[Trigger signal specification]

- (1) External trigger input
 - Input level Low level : 0 ~ 0.5V
 High level : 2.0 ~ 5.0V
 - Polarity Positive/Negative bipolar
 - Pulse width 2us (Minimum)
 - Input impedance High impedance
- (2) Software trigger Set via the IEEE1394 interface
 (IIDC1394-based Digital Camera Specification ver.1.31 conformity)

[Electronic shutter specification]

(1) AE (Auto Exposure)

- Effective range 1/20000s to OFF
- Effective area Full screen
- Exposure level -1EV to +1EV (1/3EV step)

* When the random shutter is active, AE function is disabled.

* When Raw output mode (8/10bit), AE function is disabled.

(2) Normal shutter

- PRESET setting 1/100s, 1/250s, 1/500s, 1/1000s, 1/2000, 1/4000, 1/10000, 1/20000s
(set up in the Value field of CSR register)
- Absolute value setting any value is set up in 32-bit floating point form within the range of 1/20000s to 2s.
(set up in the Absolute Value Control of CSR register)

(3) Random trigger shutter

- Fixed mode The exposure time depends on the normal shutter speed setting.
- Pulse width mode The exposure time depends on the pulse width.

[Interface specification]

- (1) Interface system 1394.b-IEEE Std 2002 conformity, Bilingual correspondence
(Connection with the IEEE1394.a environment is available)
- (2) Transmission speed S800 (800Mbps)
- (3) Video output

<CSFV90CC3>

Format	Mode	Resolution	Output method	Frame rate [fps]					
				1.875	3.75	7.5	15	30	60
Format0	Mode2	640×480	YUV 4:1:1 12 bit	◎	◎	◎	◎	◎	◎
	Mode3	640×480	YUV 4:2:2 16 bit	◎	◎	◎	◎	◎	○
	Mode4	640×480	RGB 24 bit	◎	◎	◎	◎	◎	○
Format7	Mode0	160×120~ 640×480	YUV 4:1:1 12 bit	changed by scalable setting 640 x 480 : maximum 90fps *selectable from maximum to 1/8 by band restrictions					
			YUV 4:2:2 16 bit						
			RGB 24 bit						
			Raw 8 bit						
			Raw 10 bit						

◎ : either of IEEE1394.a and IEEE1394.b is effective

○ : effective only in IEEE1394.b

<CSFX36CC3>

Format	Mode	Resolution	Output method	Frame rate [fps]				
				1.875	3.75	7.5	15	30
Format1	Mode3	1024×768	YUV 4:2:2 16 bit	◎	◎	◎	◎	○
	Mode4	1024×768	RGB 24 bit	◎	◎	◎	○	×
Format7	Mode0	256×192~ 1024×768	YUV 4:1:1 12 bit	changed by scalable setting 1024 x 768 : maximum 36fps *selectable from maximum to 1/8 by band restrictions				
			YUV 4:2:2 16 bit					
			RGB 24 bit					
			Raw 8 bit					
			Raw 10 bit					
Format7	Mode1	1024×254	YUV 4:1:1 12 bit	1/3 draft mode *maximum frame rate 86 fps				
			YUV 4:2:2 16 bit					
			RGB 24 bit					
			Raw 8 bit					
			Raw 10 bit					

◎ : either of IEEE1394.a and IEEE1394.b is effective

○ : effective only in IEEE1394.b

× : Setting is invalid

<CSFS20CC2>

Format	Mode	Resolution	Output method	Frame rate [fps]			
				1.875	3.75	7.5	15
Format2	Mode0	1280×960	YUV 4:2:2 16 bit	◎	◎	◎	○
	Mode1	1280×960	RGB 24 bit	◎	◎	◎	○
Format7	Mode0	160×120~ 1280×960	YUV 4:1:1 12 bit	changed by scalable setting 1280 x 960 : maximum 20fps *selectable from maximum to 1/8 by band restrictions			
			YUV 4:2:2 16 bit				
			RGB 24 bit				
			Raw 8 bit				
			Raw 10 bit				
Format7	Mode1	1280×480	YUV 4:1:1 12 bit	1/2 draft mode *maximum frame rate 34 fps			
			YUV 4:2:2 16 bit				
			RGB 24 bit				
			Raw 8 bit				
			Raw 10 bit				

◎ : either of IEEE1394.a and IEEE1394.b is effective

○ : effective only in IEEE1394.b

<CSFU15CC18>

Format	Mode	Resolution	Output method	Frame rate [fps]			
				1.875	3.75	7.5	15
Format2	Mode3	1600×1200	YUV 4:2:2 16 bit	◎	◎	◎	○
	Mode4	1600×1200	RGB 24 bit	◎	◎	○	×
Format7	Mode0	200×150~ 1600×1200	YUV 4:1:1 12 bit	changed by scalable setting 1600 x 1200 : maximum 15fps *selectable from maximum to 1/8 by band restrictions			
			YUV 4:2:2 16 bit				
			RGB 24 bit				
			Raw 8 bit				
			Raw 10 bit				
Format7	Mode1	1600×300	YUV 4:1:1 12 bit	1/4 draft mode *maximum frame rate 46 fps			
			YUV 4:2:2 16 bit				
			RGB 24 bit				
			Raw 8 bit				
			Raw 10 bit				

◎ : either of IEEE1394.a and IEEE1394.b is effective

○ : effective only in IEEE1394.b

× : Setting is invalid

Notes on Frame Drops of Image:

- Depends on your PC or IEEE1394 interface board configurations, images may not be captured normally (e.g. frame drops may occur). In this case, change to frame rate setting lower.

(4) Protocol

IIDC1394-based Digital Camera Specification ver.1.31 conformity

[Machine externals specification]

- (1) Dimensions 44 mm (W) * 29 mm (H) * 44 mm (D)
- (2) Mass Approximately 80 g
- (3) Lens mount C-mount

Notes on combination of C-mount lens:

- Depending on the lens you use, the performance of the camera may not be brought out fully due to the deterioration in resolution and brightness in the peripheral area, occurrence of a ghost, aberration and others. When you check the combination between the lens and camera, be sure to use the lens you actually use.

As for the C-mount lens used combining this camera, the projection distance from bottom of the screw should use 9.4mm or less.

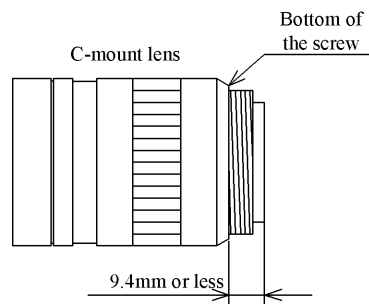

(4) Flange back it is not possible to adjust it.

(5) Camera body grounding: insulation status

Conductive between circuit GND and camera body

[Operating Ambient conditions]

(1) Ambient conditions

- Performance assurance

- Temperature 0 to 40°C
- Humidity 10 to 90% (no condensation)

- Operating assurance

- Temperature -5 to 45°C
- Humidity 90% or less (no condensation)

- Storage assurance

- Temperature -20 to 60°C
- Humidity 90% or less (no condensation)

(2) EMC conditions

- EMI (Electro-Magnetic interference)

- EN61000-6-4 conformity
- FCC part15 Subpart B class A conformity

- EMS(Electro-Magnetic susceptibility)

- EN61000-6-2 conformity

Notes on Conformity of the EMC:

- About the standard of this machine, it has guaranteed in the conditions combined with IEEE1394 Cable "1394C-9B-9B-4500mm (Manufactured by HORIZON CO., LTD)".

When used combining parts other than specification of our company, I ask you to have final EMC conformity checked of a visitor with a machine and the whole equipment.

[Connector pin assignment]

(1) IEEE1394 interface connector (Bilingual connector)

- Connector model HSR-BV011 (manufactured by COMOSS).

- Pin assignment

Pin No.	I/O	Signal Name	Function
1	I/O	TPB*	Twisted Pair B(-)
2	I/O	TPB	Twisted Pair B(+)
3	I/O	TPA*	Twisted Pair A(-)
4	I/O	TPA	Twisted Pair A(+)
5	-	TPA(R)	Twisted Pair A (Reference Ground)
6	-	V _G	Power (Ground)
7	-	SC	Status Contact (reserved)
8	I	V _P	Power (Voltage)
9	-	TPB(R)	Twisted Pair B (Reference Ground)

(2) Connector for trigger signal input

- Connector (Camera side) HR10A-7R-4PB(73) (Manufactured by HIROSE DENKI)

- Plug (Cable side) HR10A-7P-4S(73) (Manufactured by HIROSE DENKI) or equivalents

- Pin assignment

Pin No.	I/O	Signal Name	Function
1	I	TRIG IN	Trigger Input
2	-	GND	Ground
3	-	N.C.	Not Connected
4	-	N.C.	Not Connected

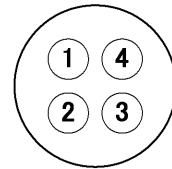

*Above figure is connector view from insert

[Typical spectral response]

The lens characteristics and light source characteristics is not reflected in table.

<CSFV90CC3>

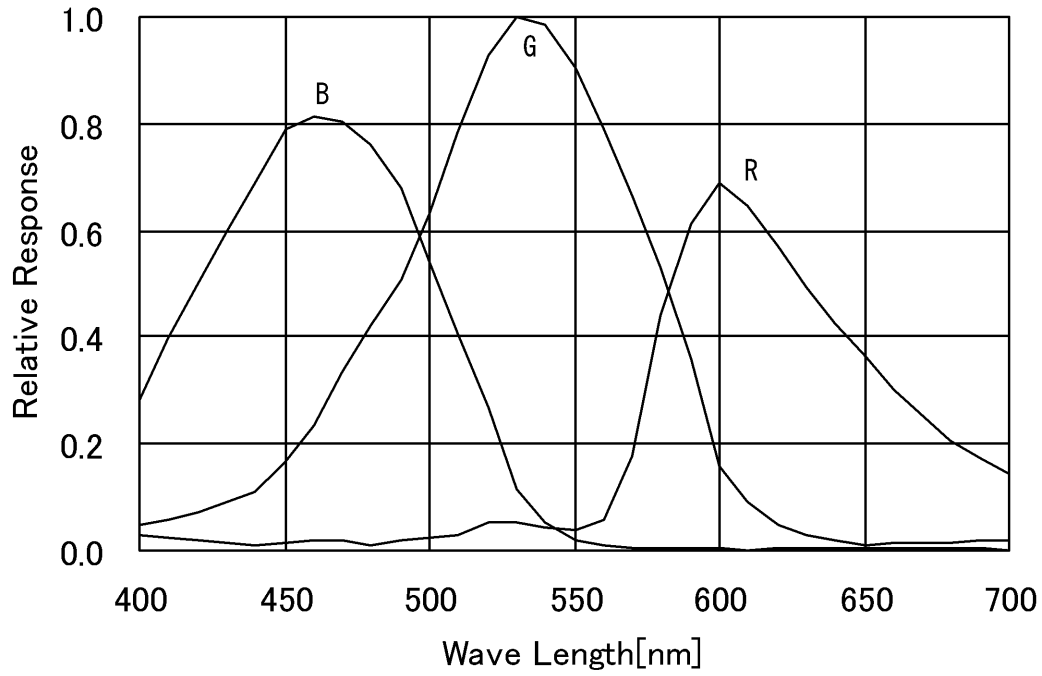

<CSFX36CC3>

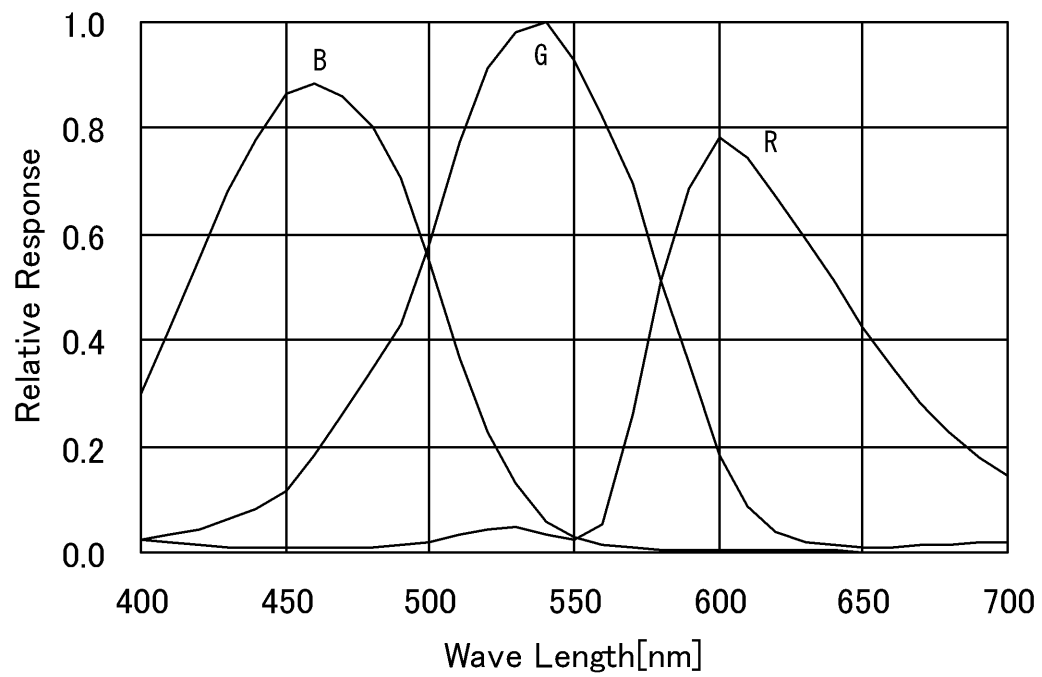

<CSFS20CC2>

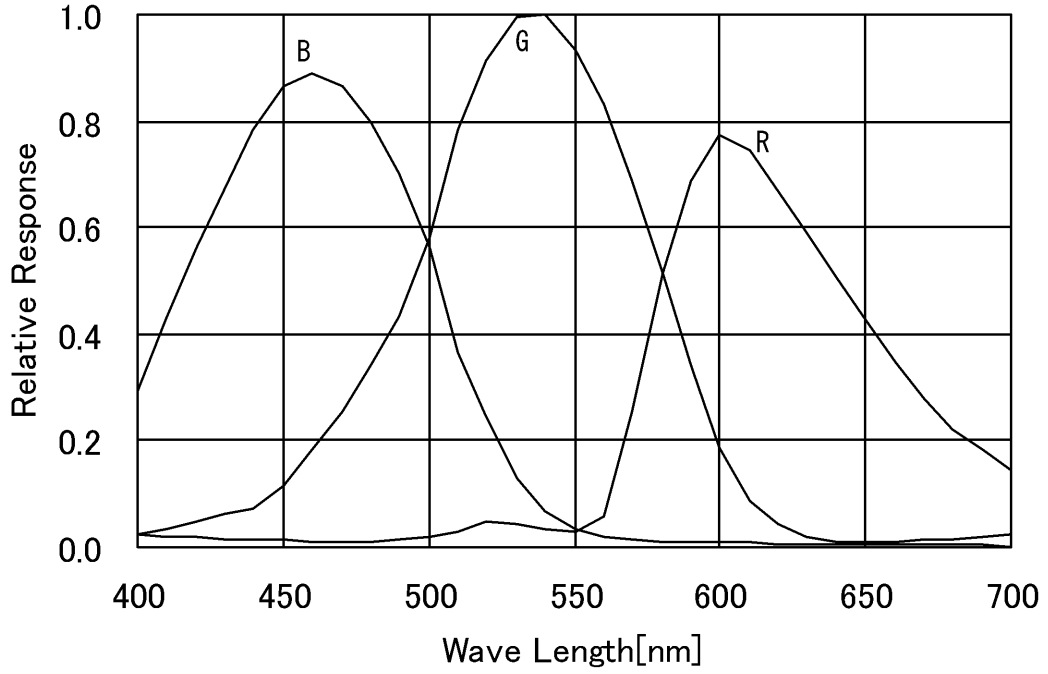

<CSFU15CC18>

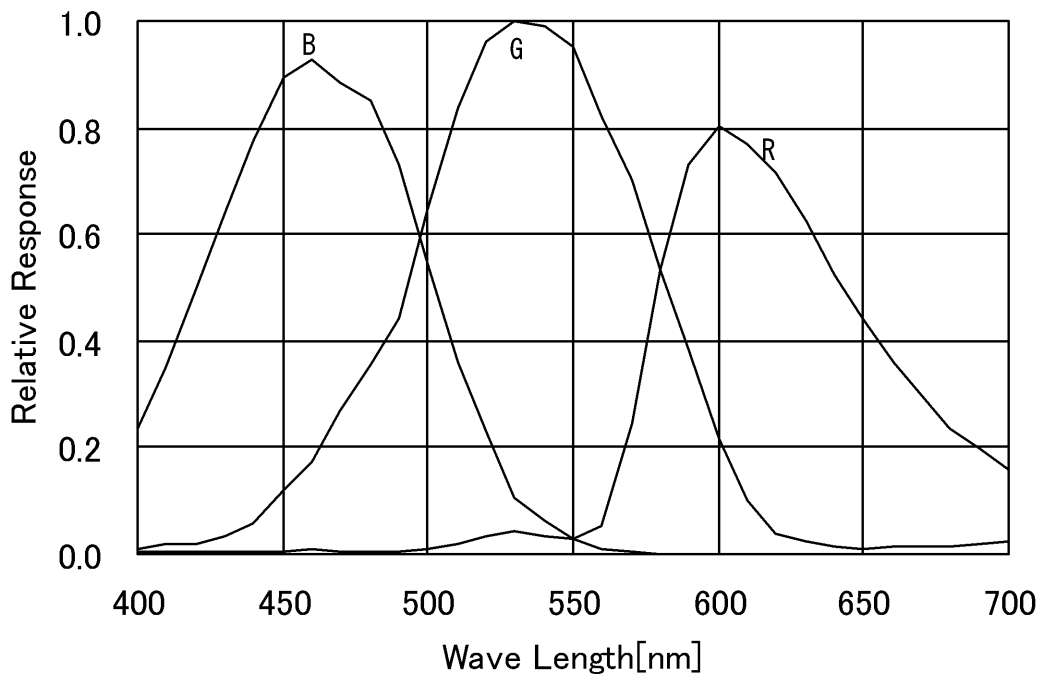

7. Timing chart

(1) In the normal shutter mode (When exposure time is shorter than frame rate)

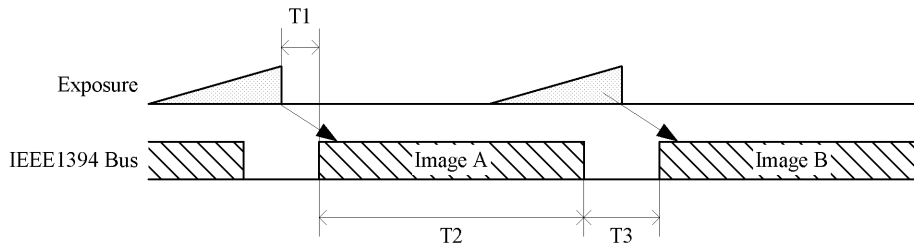

<CSFV90CC3>

- Format 0 Mode 2 and Mode 3, Mode 4

Frame rate	T1 [ms]	T2 [ms]	T3 [ms]
Rate 0 (1.875 fps)	0.5 (Maximum)	480	53.3
Rate 1 (3.75 fps)		240	26.7
Rate 2 (7.5 fps)		120	13.3
Rate 3 (15 fps)		60	6.7
Rate 4 (30 fps)		30	3.3
Rate 5 (60 fps)		15	1.7

- Format 7 Mode 0

▪ T1 = 1.4 ms (Maximum), T3 = 0.1~2 ms (Maximum)

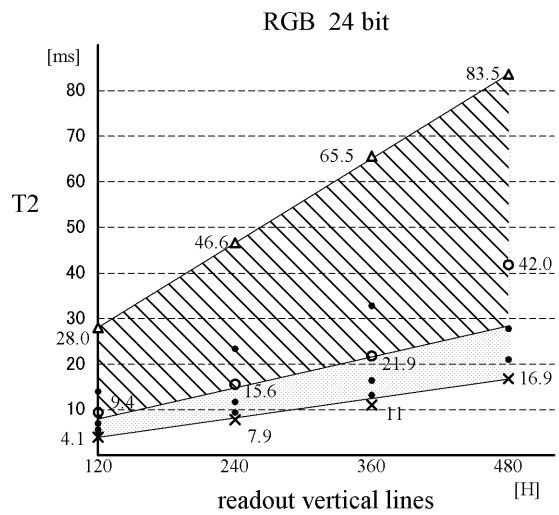
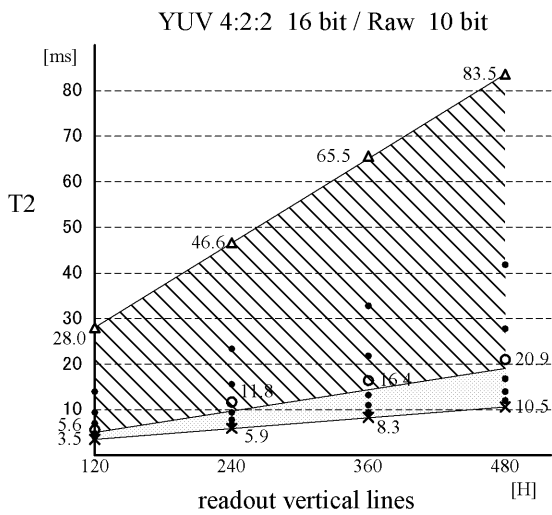
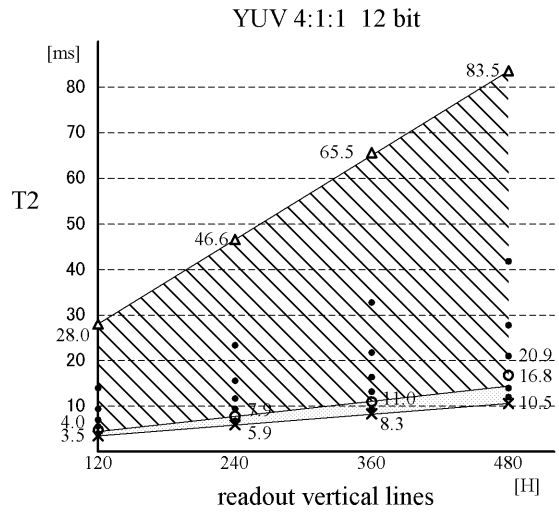
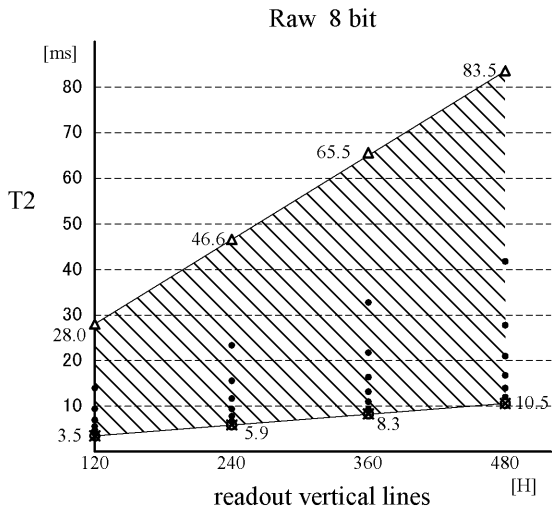

× maximum frame rate at IEEE1394.b

○ maximum frame rate at IEEE1394.a

△ minimum frame rate

● possible value at setting

▨ effective range in all mode

▩ effective range in IEEE1394.b

<CSFX36CC3>

- Format 1 Mode 3

Frame rate	T1 [ms]	T2 [ms]	T3 [ms]
Rate 0 (1.875 fps)	0.5 (Maximum)	512	21.3
Rate 1 (3.75 fps)		256	10.7
Rate 2 (7.5 fps)		128	5.3
Rate 3 (15 fps)		64	2.7
Rate 4 (30 fps)		32	1.3

- Format 1 Mode 4

Frame rate	T1 [ms]	T2 [ms]	T3 [ms]
Rate 0 (1.875 fps)	0.5 (Maximum)	512	21.3
Rate 1 (3.75 fps)		256	10.7
Rate 2 (7.5 fps)		128	5.3
Rate 3 (15 fps)		64	2.7

- Format 7 Mode 0

- T1 = 4.1 ms (Maximum), T3 = 0.1~8 ms (Maximum)

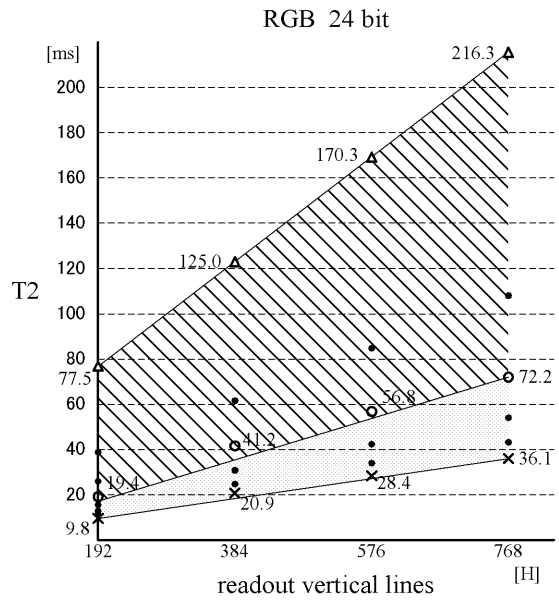
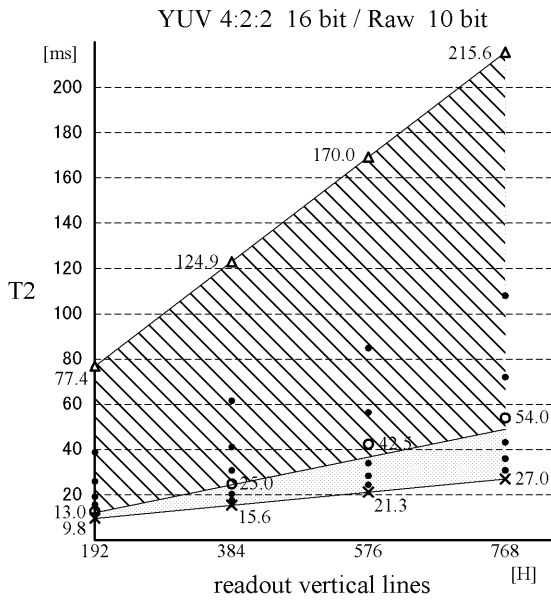
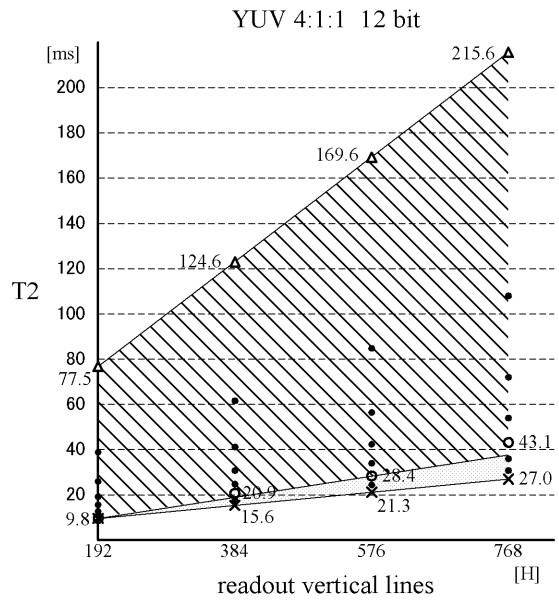
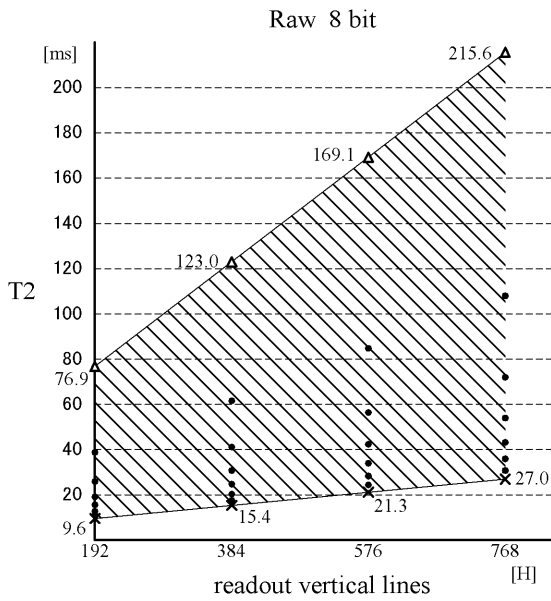

- × maximum frame rate at IEEE1394.b
- maximum frame rate at IEEE1394.a
- △ minimum frame rate

- possible value at setting
- ▨ effective range in all mode
- ▩ effective range in IEEE1394.b

- Format 7 Mode 1

- Raw 8 bit / Raw 10 bit / YUV 4:1:1 12 bit / YUV 4:2:2 16 bit

Frame rate	T1 [ms]	T2 [ms]	T3 [ms]
11 fps	0.5 (Max)	92.5	0.8
21 fps		46.3	0.3
32 fps		30.9	0.2
43 fps		23.1	0.2
53 fps		18.5	0.2
64 fps		15.5	0.1
75 fps		13.3	0.1
86 fps		11.6	0.1

- RGB 24 bit

Frame rate	T1 [ms]	T2 [ms]	T3 [ms]
24 fps	0.5 (Max)	41.0	0.75 (Max)
32 fps		30.8	
40 fps		24.6	
48 fps		20.5	
56 fps		17.6	
64 fps		15.4	

<CSFS20CC2>

- Format 2 Mode 0 and Mode 1

Frame rate	T1 [ms]	T2 [ms]	T3 [ms]
Rate 0 (1.875 fps)	1.0 (Maximum)	480	53.3
Rate 1 (3.75 fps)		240	26.7
Rate 2 (7.5 fps)		120	13.3
Rate 3 (15 fps)		60	6.7

- Format 7 Mode 0

- T1 = 5 ms (Maximum), T3 = 0.1~20 ms (Maximum)

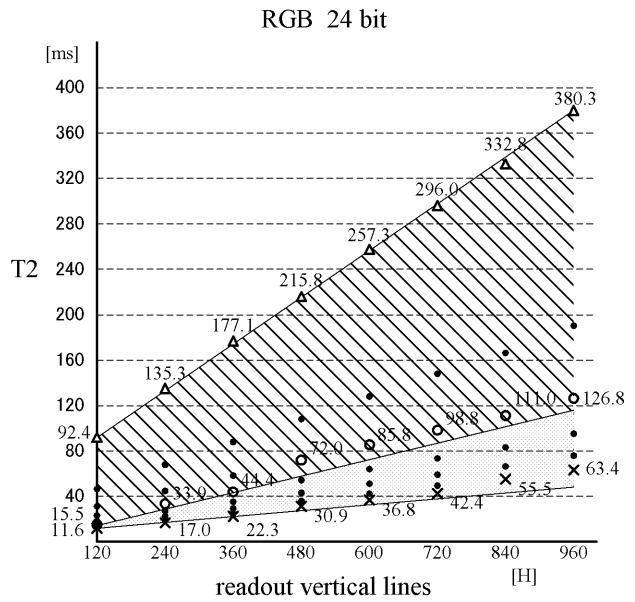
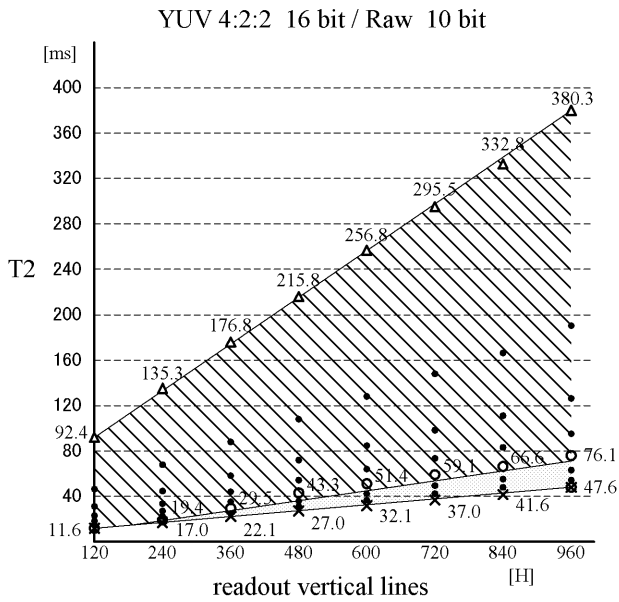
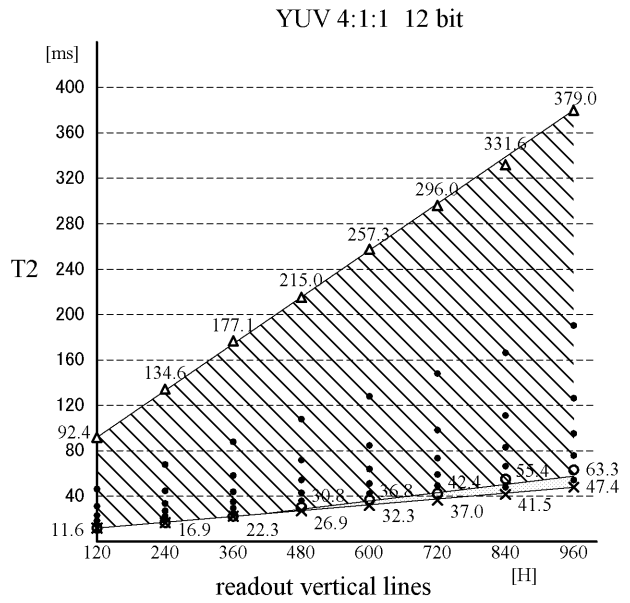
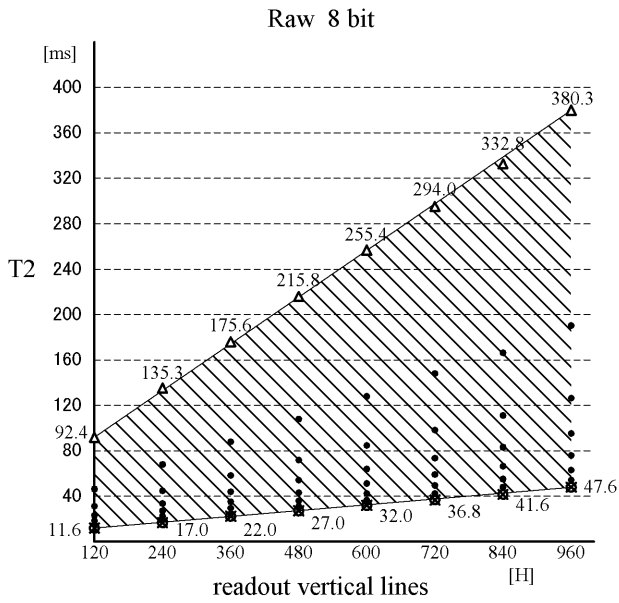

× maximum frame rate at IEEE1394.b

○ maximum frame rate at IEEE1394.a

Δ minimum frame rate

● possible value at setting

▨ effective range in all mode

▩ effective range in IEEE1394.b

- Format 7 Mode 1

- Raw 8 bit / Raw 10 bit / YUV 4:1:1 12 bit / YUV 4:2:2 16 bit / RGB 24 bit

Frame rate	T1 [ms]	T2 [ms]	T3 [ms]
4.26 fps	1.5 (Maximum)	226.9	8.0
8.5 fps		113.5	4.0
13 fps		75.6	2.7
17 fps		56.8	1.9
21 fps		45.4	1.6
26 fps		37.9	1.3
30 fps		32.5	1.1
34 fps		28.4	1.0

<CSFU15CC18>

- Format 2 Mode 3

Frame rate	T1 [ms]	T2 [ms]	T3 [ms]
Rate 0 (1.875 fps)	1.0 (Maximum)	480	53.3
Rate 1 (3.75 fps)		240	26.7
Rate 2 (7.5 fps)		120	13.3
Rate 3 (15 fps)		60	6.7

- Format 2 Mode 4

Frame rate	T1 [ms]	T2 [ms]	T3 [ms]
Rate 0 (1.875 fps)	1.0 (Maximum)	480	53.3
Rate 1 (3.75 fps)		240	26.7
Rate 2 (7.5 fps)		120	13.3

- Format 7 Mode 0

- T1 = 10 ms (Maximum), T3 = 0.1~20 ms (Maximum)

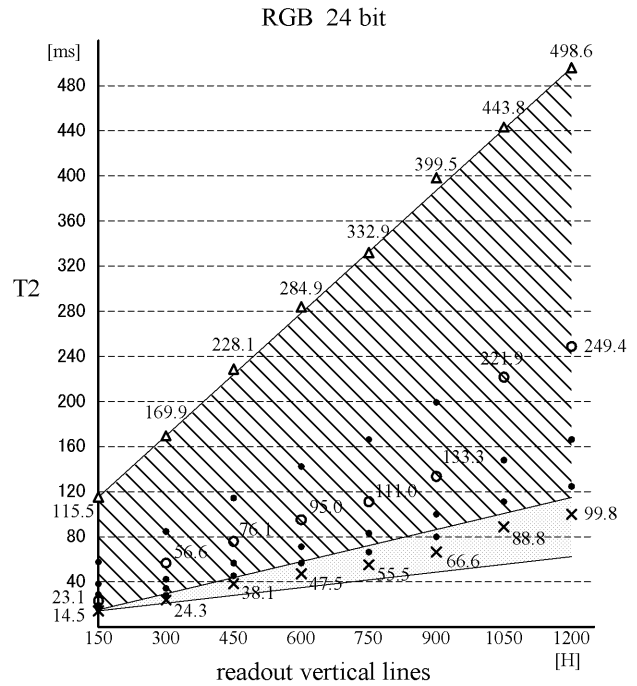
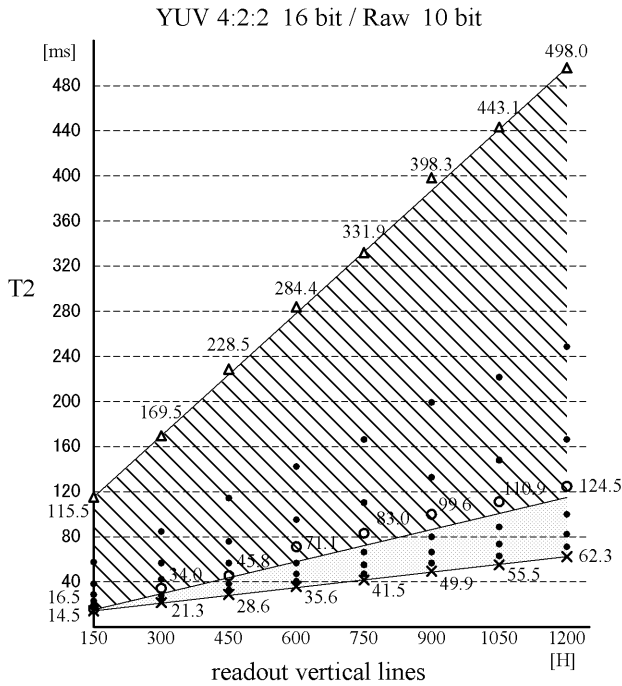
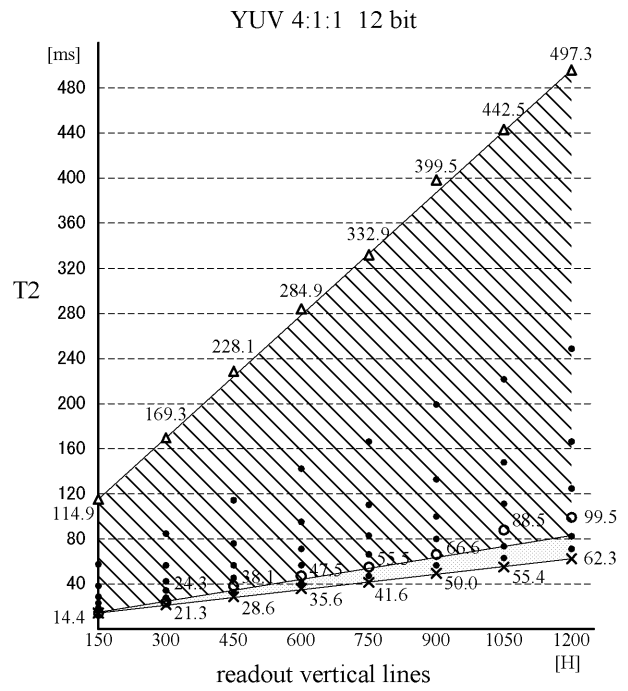
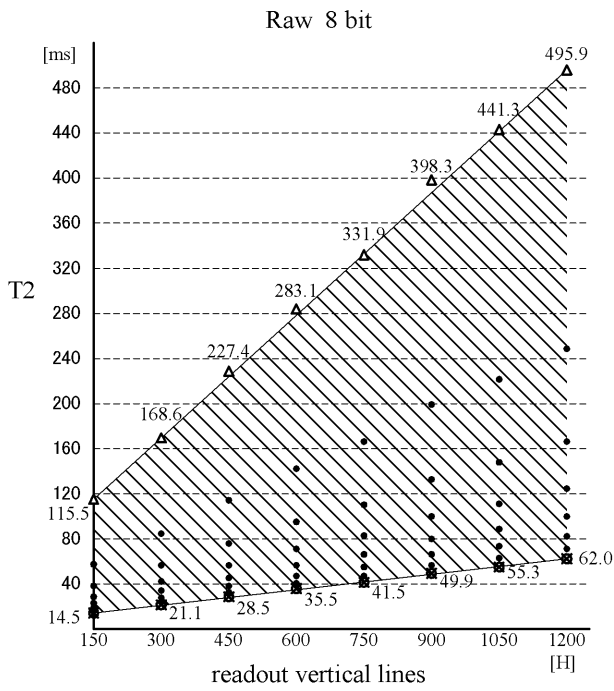

× maximum frame rate at IEEE1394.b

○ maximum frame rate at IEEE1394.a

△ minimum frame rate

● possible value at setting

▨ effective range in all mode

▩ effective range in IEEE1394.b

- Format 7 Mode 1

- Raw 8 bit / Raw 10 bit / YUV 4:1:1 12 bit / YUV 4:2:2 16 bit

Frame rate	T1 [ms]	T2 [ms]	T3 [ms]
5.8 fps	10 (Maximum)	169.3	3.8
12 fps		83.4	3.2
17 fps		56.5	1.2
23 fps		42.4	0.9
29 fps		33.9	0.7
35 fps		28.3	0.6
40 fps		24.3	0.4
46 fps		21.3	0.4

- RGB 24 bit

Frame rate	T1 [ms]	T2 [ms]	T3 [ms]
5.8 fps	10 (Maximum)	169.3	3.8
12 fps		83.4	3.2
17 fps		56.5	1.2
23 fps		42.4	0.9
29 fps		33.9	0.7
35 fps		28.3	0.6
40 fps		24.3	0.4

(2) In the normal shutter mode (When exposure time is longer than frame rate)

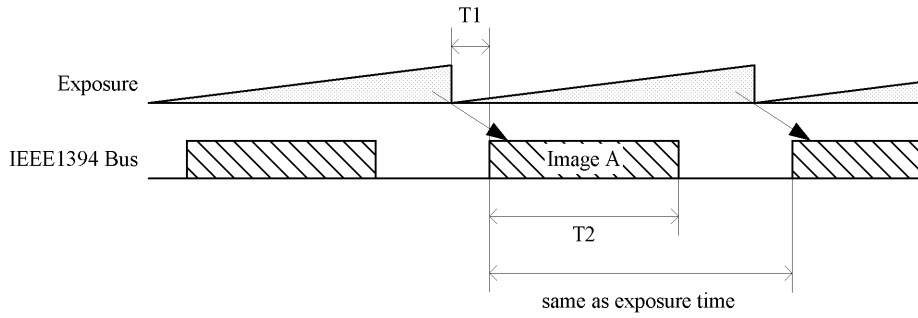

T1 and T2 are the same as it of (1) In the normal shutter mode (When exposure time is shorter than frame rate).

(3) In the random trigger shutter

- When fixed mode

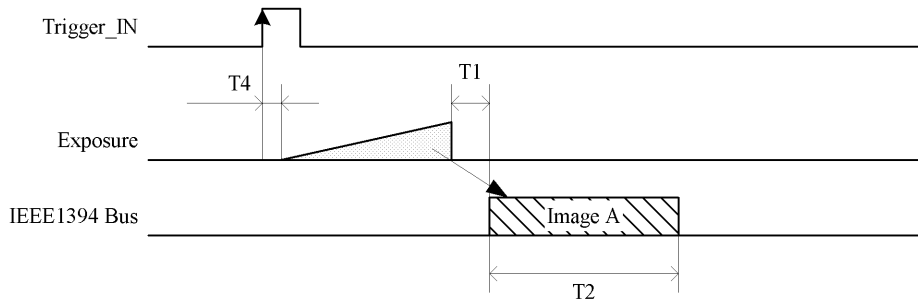

- When pulse width mode

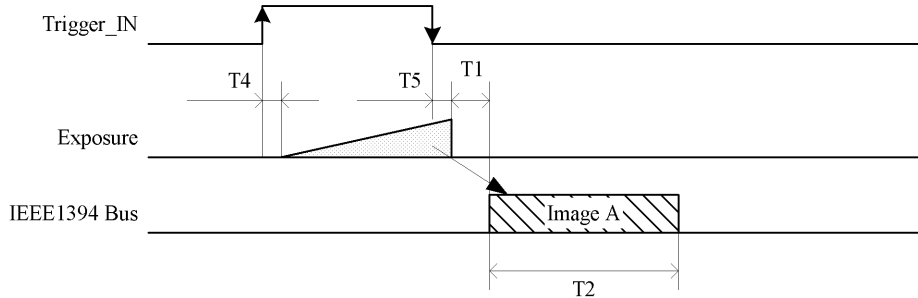

T1 and T2 are the same as it of (1) In the normal shutter mode (When exposure time is shorter than frame rate).

Model name	T4 [μ s]	T5 [μ s]
CSFV90CC3	1.0	3.0
CSFX36CC3	1.7	25.4
CSFS20CC2	3.5	5.3
CSFU15CC18	2.0	7.7

8. Outline Drawing

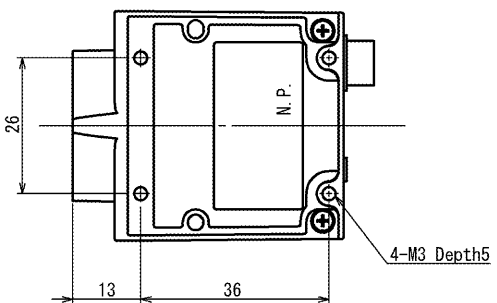
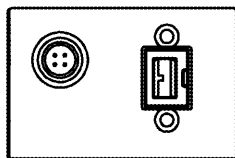
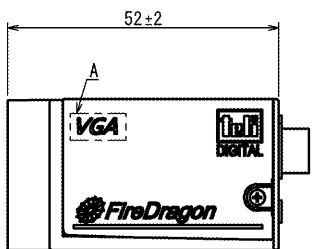
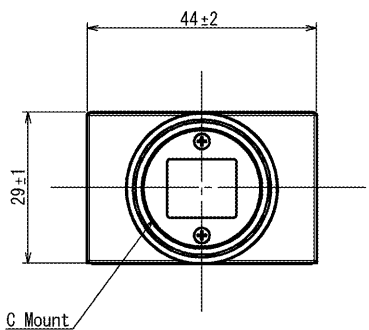
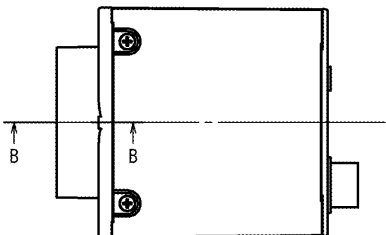
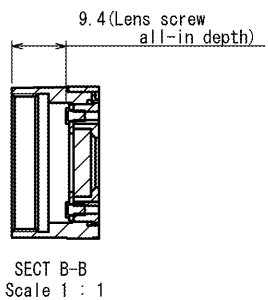

- TYPE "A"
- VGA
 - XGA
 - SXGA
 - UXGA



TOSHIBA TELI CORPORATION

Head Office : 7-1, 4 chome, Asahigaoka, Hino-shi, Tokyo, 191-0065, Japan
(Overseas Sales Department)

Phone : +81-42-589-8771

Fax : +81-42-589-8774

URL : <http://www.toshiba-teli.co.jp>

Distributor

- This product must be classified for disposal according to the laws of each country and municipal laws.
 - Information contained in this document is subject to change without prior notice.
-