

**It's no trick...
it's a vision system**



**Vision
Components**
The Smart Camera People

VC4002L Hardware Manual

**Hardware Specifications for the VC4002L Line Scan Smart
Cameras**

Draft Revision 2.1 October 2007
Document name: VC4002L_HW.pdf
© Vision Components GmbH Ettlingen, Germany

Foreword and Disclaimer

This documentation has been prepared with most possible care. However Vision Components GmbH does not take any liability for possible errors. In the interest of progress, Vision Components GmbH reserves the right to perform technical changes without further notice.

Please notify support@vision-components.com if you become aware of any errors in this manual or if a certain topic requires more detailed documentation.

This manual is intended for information of Vision Component's customers only. Any publication of this document or parts thereof requires written permission by Vision Components GmbH.

Trademarks

Code Composer Studio and TMS320C6000, Windows XP, Total Commander, Tera Term, Motorola are registered Trademarks. All trademarks are the property of their respective owners.











References

Since the VC40XX smart camera family employs a TI processor, the programming environment and functions for the VC20XX cameras can be used for this camera.

Please also consult the following resources for further reference:

“[Support News](#)” for an overview of latest updates and support information

“[Knowledge Base / FAQ](#)” for a searchable data base of SW and HW questions / answers

Description	Title on Website	Download Area
 Quick start Manual for VC camera set up and programming	 Getting Started VC Smart Cameras with TI DSP	Public Download Area ▶ Getting Started VC SDK Ti
 Schnellstart VC – deutsche Version of „Getting Started VC“.	 Schnellstart VC Smart Kameras	Customer Area ▶ Getting Started VC20XX and VC40XX Cameras
Introduction to VC Smart Camera programming	 Programming Tutorial for VC20XX and VC40XX Cameras	Customer Area ▶ Getting Started VC20XX and VC40XX Cameras
Demo programs and sample code used in the Programming Tutorial	 Tutorial_Code	Customer Area ▶ Getting Started VC20XX and VC40XX Cameras
VC4XXX Hardware Manual	 VC40XX Smart Cameras Hardware Documentation	Public Download Area ▶ Hardware Documentation VC Smart Cameras
VCRT Operation System Functions Manual	 VCRT 5.0 Software Manual	Registered User Area ▶ Software documentation VC Smart Cameras
VCRT Operation System TCP/IP Functions Manual	 VCRT 5.0 TCP/IP Manual	Registered User Area ▶ Software documentation VC Smart Cameras
VCLIB 2.0 /3.0 Image Processing Library Manual	 VCLIB 2.0/ 3.0 Software Manual	Registered User Area ▶ Software documentation VC Smart Cameras



- The Light bulb highlights hints and ideas that may be helpful for a development.
- This warning sign alerts of possible pitfalls to avoid. Please pay careful attention to sections marked with this sign.

Author: Peter Neuhaus, VC Support, <mailto:support@vision-comp.com>

Table of Contents

1	General Information	4
2	Technical Specifications VC4002L Line Scan	5
3	VC4002L Camera Interfaces	6
3.1	LAN / Ethernet Interface	7
	3.1.1 Pin Assignments LAN / Ethernet Interface	7
	3.1.2 Available Accessories for LAN / Ethernet socket	7
3.2	Trigger-/ V24 (RS232)-/ Keypad Interface	8
	3.2.1 Pin Assignments Trigger-/ V24 (RS232)-/ Keypad/ - Encoder Interface	8
	3.2.2 Trigger Cable	8
	3.2.3 V24 (RS232) serial Cable	9
	3.2.4 Y-Cable	9
	3.2.5 Electrical Specifications of Trigger- / Serial-/ Keypad / Encoder Interface	10
3.3	Power Supply and IO Interface	11
	3.3.1 Pin assignments Power Supply and IO Interface	11
	3.3.2 Electrical specifications Power Supply Camera	11
	3.3.3 Electrical Specifications digital PLC IO Interface	12
	3.3.4 Available Accessories / Cables for Power Supply and IO Interface	12
4	Order Numbers Cameras and Accessories	13
4.1	Order number VC4002L:	13
4.2	Order numbers of all available VC4002L Accessories	13
5	Programming the VC4002L Line Scan Camera	16
5.1	Shutter Speed adjustment	16
5.2	Gain Adjustment	16
5.3	Image acquisition	17
5.4	Trigger Mode Selection	17
	5.4.1 Software trigger mode (capture mode 1)	18
	5.4.2 Hardware trigger mode with variable exposure time (capture mode 2)	19
	5.4.3 Hardware trigger mode with fixed exposure time (capture mode 3)	20
5.5	Image Memory Allocation and Height Adjustment	21
6	Demo Program for different Capture Modes	V
Appendix A:	Block diagram VC4002L Line Scan Cameras	A
Appendix C:	Overall Dimensions Housing VC4002L	A
Appendix E:	Drawing Camera Head VC4002L	B
Appendix F:	Mounting direction of the VC4002L	B
Appendix G:	Spectral Transmission of IR Filter	C
INDEX		D

1 General Information



VC4002L compared with the standard housing size



VC4002L Smart Camera series rear view

The launch of the very first VC Line Scan Smart Camera represents another significant extension of Vision Component's product range.

The range of smart camera applications now also include typical line scan camera applications. The advantages of the VC4002L include:

- Most existing VCRT and VCLIB functions can still be used with this camera.
- Flexible image height from 1 to 16,000 lines.
- Up to 11 kHz scanning frequency.
- Due to our special design, 1" C-mount lenses can be used – special scan lenses are not required.
- Most typical VC4000 camera interfaces are included (8 digital IO's, 100 Mbit Ethernet and RS232, high speed trigger interface).
- High processor performance using the 400MHz, 3200MIPS TMS 320C64 from Texas Instruments.
- A direct Video output is not incorporated, however live images can be transferred by TCP/ IP and displayed on the PC monitor with the "ATX-Client".
- 3 different trigger modes / accurate synchronisation with moving equipment via trigger input.

Refer to the [Appendix A](#) for a hardware structure diagram of the VC4002L Smart Camera.

2 Technical Specifications VC4002L Line Scan

Component / Feature	Specification
Sensor:	CMOS, Resolution 2048x1
Fill factor	99 %
eff. no. of pixels:	2048
Pixel size:	7 x 7 μm
Chip size:	Width: 14.336 mm
Shutter:	From 90 microseconds to 21ms
Picture taking:	1 program-controlled and 2 trigger controlled modes (interrupt);
Clamping:	High precision differential amplifier
A/D conversion:	25 MHz / 10 bit, only 8 bits used for grey values
Input LUT	none
Image Display	Via 100 Mbit Ethernet onto PC
Processor:	Texas Instruments 400 MHz TMS320 C64 DSP
RAM:	32 Mbytes SDRAM (synchronous dynamic RAM)
Memory capacity:	Depending on image size – up to 16,383 lines
Flash EPROM:	4 Mbytes flash EPROM (nonvolatile memory) for programs and data, in-system programmable, 3 MB available to user
MMC:	Not available
Process interface:	4 inputs / 4 outputs, outputs 4x400 mA
Trigger Input	Fast 5 V TTL input and output, jitter free image acquisition
Serial Interface:	Up to 115,200 bd serial RS232 communication port
Ethernet interface:	100 Mbit
Video output	No direct video output / download of live images via Ethernet possible
CE certification:	CE Certification from Vision Components
Storage Conditions	Temperature: -20 to 60 deg C, Max. humidity: 90%, non condensing.
Operating Conditions	Temperature: 0... +45 deg C (surrounding temperature), Max. humidity: 80%, non condensing.
Power Supply	12V... 24V , min: 10V, max: 30V
Power Consumption	\approx 3 W (current drawn from PLC outputs additional)

3 VC4002L Camera Interfaces

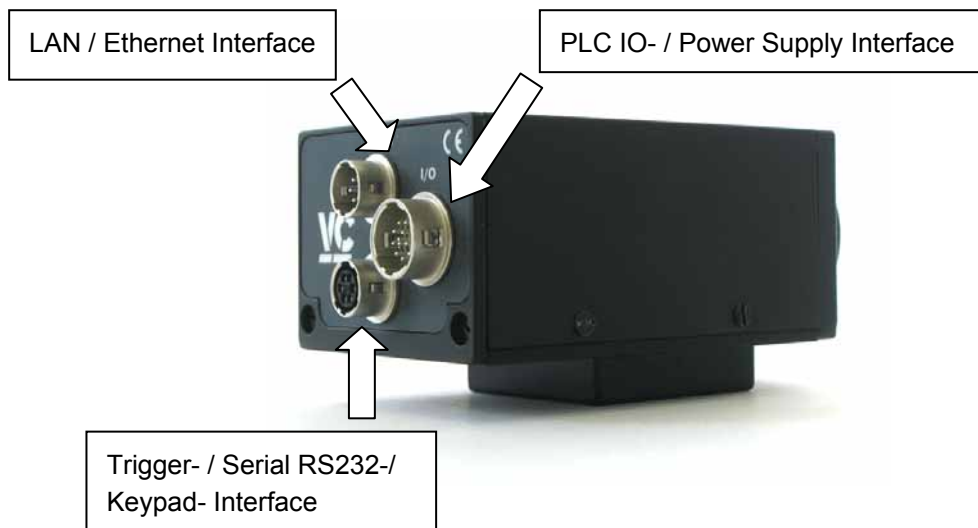

The VC4002L Smart Camera incorporates the following connector interfaces:

1. LAN / Ethernet Interface
2. Trigger- Serial V24 (RS232) and Keypad Interface
3. PLC IO and Power Supply Interface

The pin assignments, electrical specifications as well as available accessories are shown for each interface connector in the following sections.

Please also refer to the [Product/Hardware/ Order Numbers for VC40XX Accessories/Cables page](#) for an up to date list of cables and further information available.

3.1 LAN / Ethernet Interface

3.1.1 Pin Assignments LAN / Ethernet Interface

Signal	Pin
T+	2
T-	1
R+	6
R-	5
-	3
-	4

rear view camera socket:

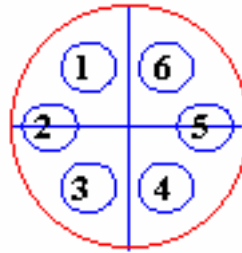

3.1.2 Available Accessories for LAN / Ethernet socket

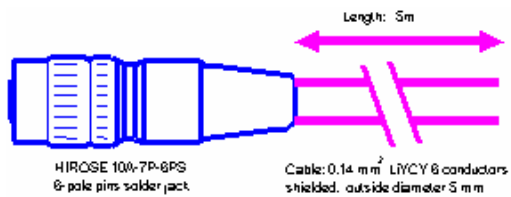

Signal	Pin (to cam.)	Pin (to PC)	Cable Color 20m patch cable	Cable Color 10m patch cable
T+	2	1	yellow	white/pink
T-	1	2	orange	pink
R+	6	3	white/green	white/green
R-	5	6	green	green
-	3	NC	-	-
-	4	NC	-	-

Refer to section 4.2 for a list of available cables with order numbers.

3.2 Trigger-/ V24 (RS232)-/ Keypad Interface

The trigger interface incorporates 3 different functions:

1. Line trigger input for hardware controlled image acquisition.
2. Serial RS232 interface (can not be used at the same time as the encoder interface).
3. Keypad interface (uses the serial input of the serial interface).

Synchronisation with an incremental encoder can be done with the standard trigger input – the special encoder interface of the VC4000 series is therefore not incorporated.

Multiple use of the trigger interface:

A “Y” adaptor cable is available for connecting several components to the trigger interface – refer to section 3.2.4 for details. The use of the serial input and the encoder interface is not possible at the same time.

3.2.1 Pin Assignments Trigger-/ V24 (RS232)-/ Keypad/ - Encoder Interface

Pin	Signals RS232 / Standard Trigger
1	V24 TxD Out
2	+ 5V Out
3	GND
4	V24 RxD In / Keypad in
5	Trigger Out
6	Trigger In

rear view trigger socket:

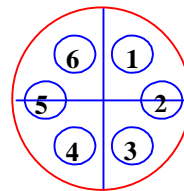

3.2.2 Trigger Cable

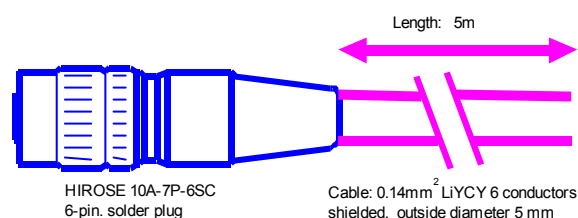

Pin	Signal	Cable Color ¹
1	V24 TxD Out	green
2	+ 5V Out	brown
3	GND	white
4	V24 RxD In	pink
5	Trigger Out	grey
6	Trigger In	yellow

Equipped on one end with a Hirose plug, length 5m, 10m or 25m
Refer to section 4.2 for a list of available cables with order numbers.

¹ Note that the color coding for both cables has been chosen according to the VC20XX core colors. For this reason the core colors of serial and trigger cables do not correspond to the same pin!

3.2.3 V24 (RS232) serial Cable

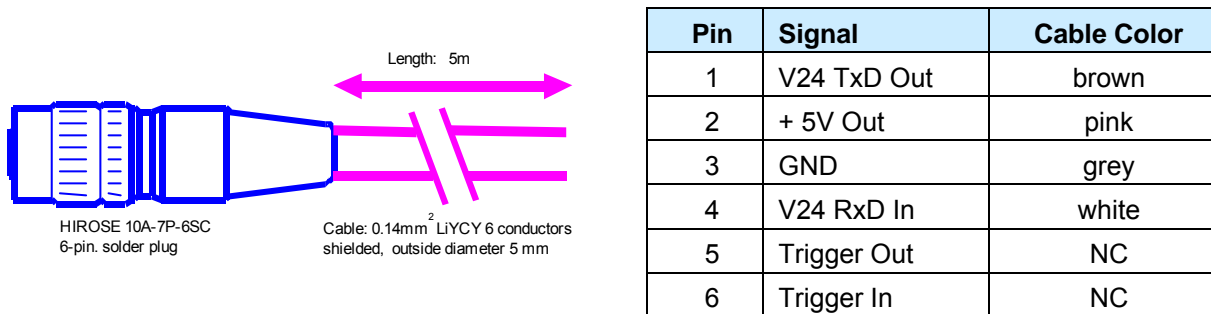

Equipped on one end with a Hirose plug, length 5m, 10m or 25m and on the other end with a 9 pin D-sub connector. This cable can also be ordered without the D-sub connector.

Refer to section 4.2 for a list of available cables with order numbers.



Refer to the VC4XXX Hardware manual for information about programming the serial interface.

3.2.4 Y-Cable

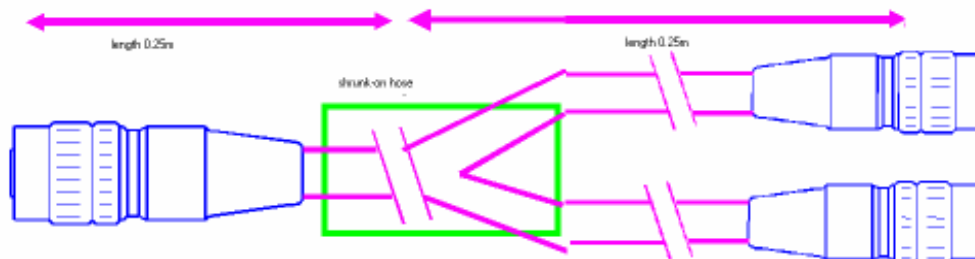

Connectors:

1x HR10A-7P-6P, male connector

2x HR10A-7J-6S, female socket

Cable length: 0.5m

The color coding of this cable corresponds to the Trigger Cable described above. All cables are connected through – from the camera output to both extension sockets. Beware of possible undesired electrical contacts when connecting different equipment at the same time.

Refer to section 4.2 for a list of available cables with order numbers.

3.2.5 Electrical Specifications of Trigger- / Serial- / Keypad / Encoder Interface

The trigger interface features a dedicated fast TTL trigger input (for use as image capture trigger) and a fast TTL trigger output (as strobe-light trigger). Since both signals are fast at a very low noise margin, it is recommended to keep the cable as short as possible. Use shielded cable for this purpose. The trigger input assures a constant capture delay without jitter.



Trigger input and output are protected with help of an inbuilt-in photo coupler. However input and output are not protected against over current, short circuits, reverse voltage or voltage spikes from inductive loads. Please ensure that the electrical specifications of this section are met.

Technical data of trigger input:

input voltage:	2.4 - 5 V (TTL, CMOS)
input current:	3mA @ 3V / 5mA @ 5V
limiting resistor:	680 R
pull down resistor 1 kΩ	Included
Opto- isolation:	Yes
reverse voltage protection:	none
switching delay:	Max. 2μsec



Refer to the VC4XXX Hardware Documentation for recommended Sample Trigger input circuits.

Technical data of trigger output:

output voltage:	max. 7V
output current:	max. 50mA
pull-up resistor:	4k7 to internal 5V

3.3 Power Supply and IO Interface

This connector includes the camera Power Supply and digital PLC IOs.

3.3.1 Pin assignments Power Supply and IO Interface

Pin	Signal
1	12-24V PLC
2	12-24V IN Cam
3	GND IN com.
4	INP 1
5	OUT 3
6	OUT 2
7	OUT 1
8	OUT 0
9	12-24V PLC
10	INP 3
11	INP 2
12	INP 0

rear view camera socket:

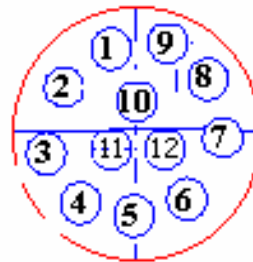

3.3.2 Electrical specifications Power Supply Camera

Power must be connected to the 12pin I/O connector. Note, that the voltage is 24V.

Camera power is regulated and galvanically separated inside the camera, so only an unregulated power source of 12...24 V is required.

The camera is, however, very sensitive to power supply interruption. Please make sure, that the voltage never exceeds the limits, refer to 2 even for a short period of time. In case of unstable power supply it is recommended to backup the power supply by a capacitor or a battery large enough to prevent power interruptions.



Note that the PLC output circuit is connected to the camera power supply! This means it is not possible to connect a different PLC output voltage to the PLC outputs.

3.3.3 Electrical Specifications digital PLC IO Interface

The VC40XX series Smart Camera features optically isolated inputs and outputs that allow for instance direct input of light barrier signals or the control of pneumatic valves.

Please observe the current and voltage ratings specified in the following sections.

The two “12-24V PLC” pins (pin 1 and pin 9) serve as power supply for the PLC outputs. These contacts are internally connected – it is recommended to supply the output voltage to both pins when the total current of all outputs exceeds 0.5 A. This represents the maximum current rating for one PLC output. The maximum combined current of all outputs should not exceed 1 A.



Refer to the VC4XXX HW documentation for sample circuits that show the connection of PLC inputs and outputs.

3.3.4 Available Accessories / Cables for Power Supply and IO Interface

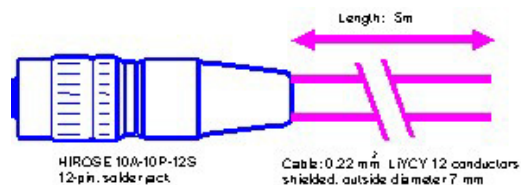

Signal	Pin No.	Cable color
OUT0	8	white
OUT1	7	brown
OUT2	6	green
OUT3	5	yellow
IN0	12	grey
IN1	4	pink
IN2	11	blue
IN3	10	purple
24V IN Cam	2	red/blue
GND IN com.	3	black
24V PLC	1	red
24V PLC	9	grey /pink

Equipped on one end with a Hirose plug jack, length 5m, 10m or 25m

Refer to section 4.2 for a list of available cables with order numbers.

4 Order Numbers Cameras and Accessories



4.1 Order number VC4002L:

Article Description	Order Number
VC4002L	VK000288

4.2 Order numbers of all available VC4002L Accessories

For interface cables and connectors available also consult the corresponding section in chapter 3 of this manual as well as the “*VC Smart Camera Accessories*” section – under the “Product” section on our website www.visoin-comp.com .

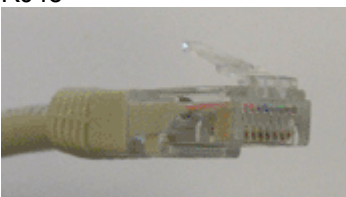
Ethernet Cables (Refer to section 3.1.2):

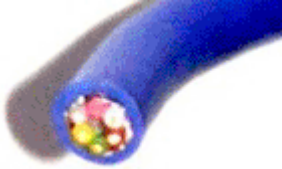

Article Description	Order Number	Camera Connector	Second Connector
5m LAN-C6-Cable	VK000149	HRS connector female 6 pin 	RJ45 
10m LAN-C6-Cable	VK000150	HRS connector female 6 pin	RJ45
20m LAN-C6-Cable	VK000151	HRS connector female 6 pin	RJ45
Ethernet Cross Module	VK000156	 RJ45	RJ45 female socket

Trigger Cables (Refer to section 3.2.2):

Article Description	Order Number	Camera Connector	Second Connector
5m Trigger-Cable / C6	VK000115	HRS connector male 6 pin 	without connector 
10m Trigger-Cable / C6	VK000164	HRS connector male 6 pin	without connector
25m Trigger-Cable / C6	VK000153	HRS connector male 6 pin	without connector

V24 (RS232) Serial Cable (Refer to section 3.2.3):

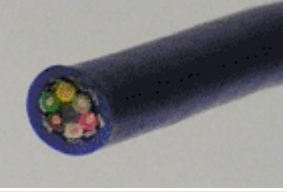
These cables differ from the serial VC20XX C6 cables!

Article Description	Order Number	Camera Connector	Second Connector
5m V24 cable	VK000243	HRS male 6 pin 	without connector 
5m V24 cable with DSUB	VK000244	HRS male 6 pin 	D-SUB 9 pin female 
10m V24 cable	VK000239	HRS male 6 pin	without connector
10m V24 cable with DSUB	VK000240	HRS male 6 pin	D-SUB 9 pin female
25m V24 cable	VK000241	HRS male 6 pin	without connector
25m V24 cable with DSUB	VK000242	HRS male 6 pin	D-SUB 9 pin female



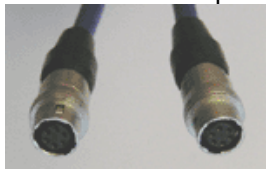

Y-Cable for connecting several cables to the Trigger / Serial Interface (Refer to section 3.2.4):

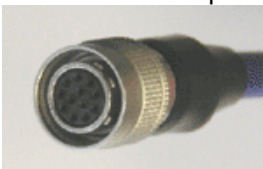
Article Description	Order Number	Camera Connector	Second Connector
0.5m Y adapter cable	VK000124	HRS male 6 pin 	2 HRS female 6 pin 

Power Supply and IO Interface Cables (refer to section 3.3.4):

Article Description	Order Number	Camera Connector	Second Connector
5m Power / PLC-Cable C6	VK000008	HRS female 12 pin 	without connector 
10m Power / PLC-Cable C6	VK000114	HRS female 12 pin	without connector
25m Power / PLC-Cable C6	VK000161	HRS female 12 pin	without connector

Further Accessories:

Article Description	Order Number	Camera Connector
Power Adapter C6 24V, with 12 pins conn. 3m	VK000119	HRS connector female 12 pin 
Power adapter for rail mounting, Input Voltage 100 - 240VAC 50/60 Hz, Output Voltage DC 24V +/-5%, max. 300 mA (7.5 W), Equipped with connecting clamps for AC input and 24V output, CE cert.	VK000036	
VCSKBC4 Keypad (different from VCSKBC6 for VC20XX cameras!) 	VK000238	
IR cut filter (camera is shipped with this filter mounted) refer to Appendix E	EK000625	
Clear glass filter (replaces IR Cut filter)	EK000624	

5 Programming the VC4002L Line Scan Camera

Most VCRT and VCLIB functions can still be used with the VC4002L line scan camera.

This section describes the changes required for programming the line scan camera.

- Shutter speed adjustment
- Gain adjustment
- Image acquisition – selecting trigger modes
- Image memory allocation / image height (vwidth) adjustment
- Adjustments required for using TCP / IP image transfer

5.1 Shutter Speed adjustment

The following functions can be used as usual to adjust the exposure time:

- sh <number> , shell command, number is the **line exposure time** in microseconds
- long shutter(long stime); stime is the line exposure time in microseconds
- int capture _request (int exp, int gain, int *start, int mode)
 - int exp equals the system variable EXPCNT (includes the shutter time)
 - int gain – equals sysvar GAIN, sensor gain (here different as for CCD cameras)
 - int *start – pointer to the corresponding image start address (CAPT_START)
 - int mode, software trigger mode = 0, hardware trigger mode =1

The value specified with “sh” or “shutter” represents the exposure time for the sensor line in microseconds.

5.2 Gain Adjustment

There are 4 different gain modes that can be adjusted with “vd -g <number>”:

- Gain = 0: number = 0, least significant 8 bits of digitized 10 bit grey levels
- Gain = 1: number = 1, medium significant 8 bits of digitized 10 bit grey levels
- Gain = 2: number = 2, most significant 8 bits of digitized 10 bit grey levels
- Gain = 3: number = 3, generating a test ramp from grey value 0 to 255

The gain setting is purely digital (no Lookup Table) and there is not an electrical amplification as with the CCD area sensors.

5.3 Image acquisition

Calling an image acquisition function like `tpict` or `capture_request`, acquires the number of image lines specified by the system variable `VWIDTH`. The width of the image taken is determined by the sensor resolution `HWIDTH`, that for the VC4002L is identical with the memory pitch `VPITCH = 2048`.

This way, only one function call is needed in order to acquire and save the image required:



A `tpict()` or `capture_request` does not only take one image line. The of lines taken with one function call corresponds to the value of the `VWIDTH` system variable (default: 512 lines).

The image height is easily reduced by reducing `VWIDTH`. In order to increase the image height, additional memory allocation is required (refer to section 5.5).

With hardware triggered image acquisition this means, one `capture_request()` call is waiting by default for 512 trigger input signals!

At camera start up, one image memory page is allocated automatically. The height of the image pre-allocated is 512 pixel (`VWIDTH`). This 1 Mbyte image memory can not be de-allocated.

Adjusting the image height from 1 to 512 lines can be done just by setting `VWIDTH` to the corresponding value.

In order to increase the image height to 513 to 16384 lines (representing the full DRAM capacity of 32 Mbytes) allocation of a new image page is required in addition to the `VWIDTH` adjustment.

The demo program in section 5.5 shows how to increase the image height.

5.4 Trigger Mode Selection

There are 3 different trigger modes available:

1. Capture mode 1: "SW trigger mode or live mode" - up to 11kHz (one line exposed after the other, shutter value determines scanning frequency),
2. Capture mode: 2: "HW trigger mode, variable exposure time" - up to 11kHz (depending on trigger signal)
3. Capture mode 3: "HW trigger mode, fixed exposure time" - up to about 5,4kHz (accurate setting of shutter possible)

The third mode is a special feature of the VC4002L, since usually the exposure time is determined by the trigger signal timing only.

The 3 modes are explained in the following sections.



Refer to section 6 for a working demo program for image acquisition with different capture modes!

5.4.1 Software trigger mode (capture mode 1)

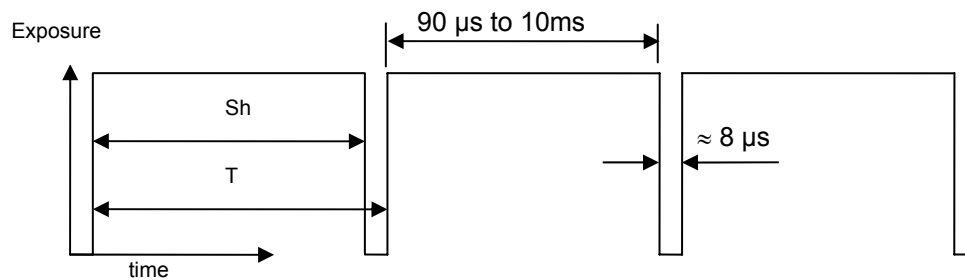

In software trigger mode, one line is exposed after the next, with only a small amount of time in between that is required to read out the pixel charges from the sensor.

The shutter setting determines the scanning frequency. The minimum shutter of 90 microseconds for instance represents a scan rate of around 11 kHz.

Live mode can be selected with the shell function "vd -l", void `vmode(0)`, or selecting "software trigger mode = 0" with the `capture_request` function.

There is only a very small gap between line exposures (image exposures) of around 8 microseconds.

Do not exceed the shutter time limits $90\mu\text{s} < \text{Shutter time} < 10,000\mu\text{s}$.

5.4.2 Hardware trigger mode with variable exposure time (capture mode 2)

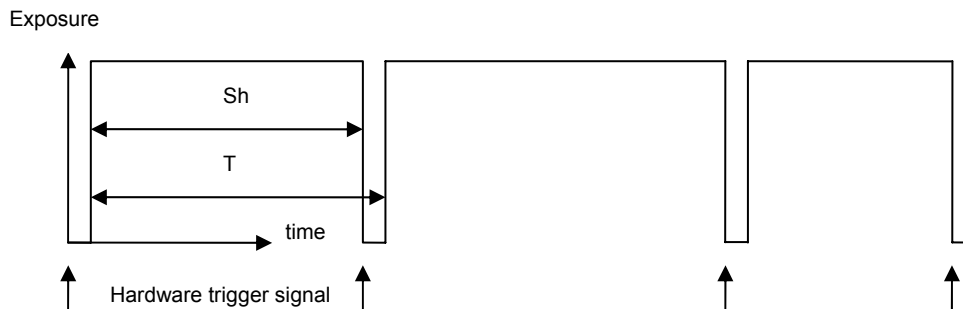

This mode represents the standard mode for hardware triggered line scan image acquisition. As the software acquisition mode the maximum scanning frequency remains 11 kHz. However since the exposure time is determined by the trigger timing, irregular trigger signals lead to varying shutter times. This can for instance lead to increased line brightness when a conveyor belt slows down and vice versa.

This trigger mode has to be selected using `capture_request` and the following parameter:

- **int exp = 0, since the exposure time does not depend on shutter values!**
- int mode = 1 – hardware trigger

Do not exceed the maximum signal frequency of 11kHz!

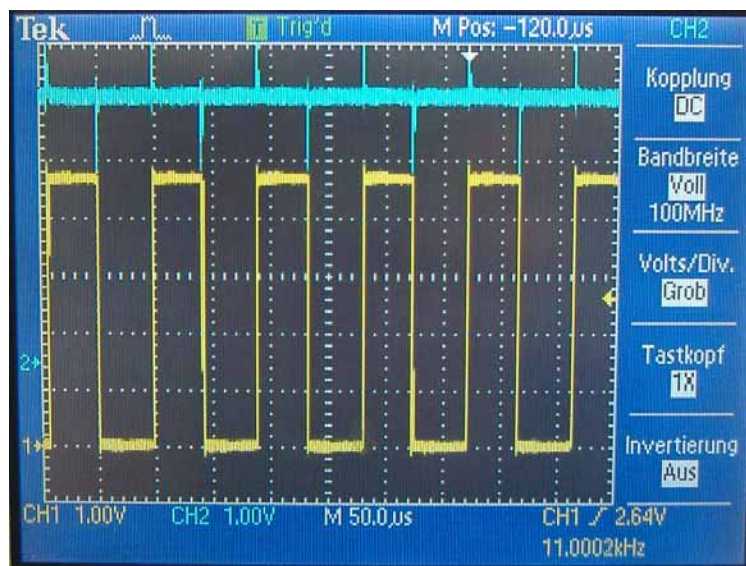

Oszilloscope screenshot capture mode 2 (11kHz, sh = 90 μ s, trigin = yellow, trigout = blue)

5.4.3 Hardware trigger mode with fixed exposure time (capture mode 3)

As mentioned above, the standard method of hardware trigger scanning can have the disadvantage of varying line brightness if the trigger timing is inconsistent. In order to achieve constant line brightness with varying trigger timing, this mode allows to acquire scans with a fixed exposure time. This scanning mode however halves the maximum scanning frequency to 5.4 kHz.

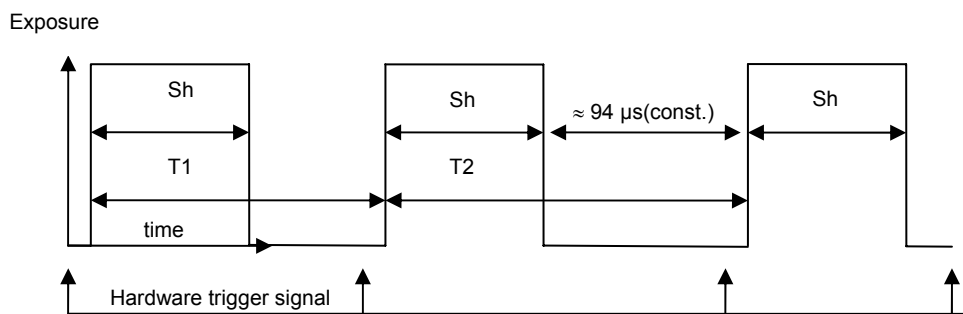

This trigger mode has to be selected using `capture_request` and the following parameter:

- `int exp = getvar(EXPCNT)`, set the shutter value with the „shutter()“ function prior to calling `capture_request!`
- `int mode = 1` – hardware trigger

Do not exceed the maximum signal frequency of 5.4 kHz in this capture mode!

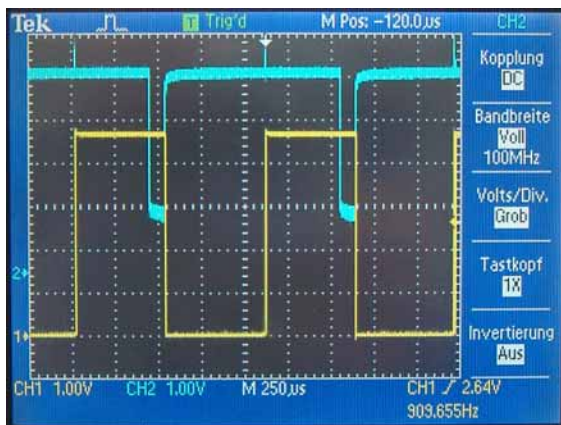

capture mode 3 (910Hz, sh = 1000 μs ,
TRIGINP_NEG(), TRIGOUT_POS())

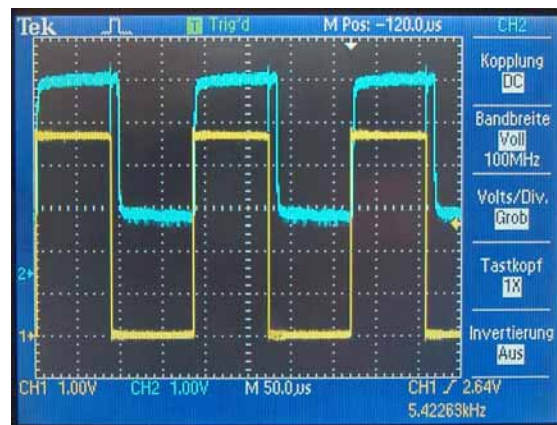

capture mode 3 (5,422kHz, sh = 90 μs ,
TRIGINP_POS(), TRIGOUT_POS())

Timing examples:

trigger mode 1: VWIDTH = 512, shutter = 1000, t-image = 512 milliseconds (capture and transfer).

trigger mode 2: VWIDTH = 512, Trigin signal 1kHz, t-image = 512 milliseconds (capture and transfer).

trigger mode 3: VWIDTH = 512, sh 90 microseconds, Trigin signal 5,423kHz (max frequency for sh 90), t-image = 94 milliseconds (capture and transfer).

5.5 Image Memory Allocation and Height Adjustment

The following steps are required in order to adjust the image height:

1. turn the camera into still mode with either:
 - using the shell command “vd -d”,
 - the function “void vmode(1)”
 - or by calling “tpict”
2. Allocate sufficient memory using the function “sysmalloc”
3. Change the system variable “VWIDTH” to the correct number of image lines (using setvar()).
4. Take an image using tpict or call the capture_request() function with the following parameter:

```
int capture_request (getvar(EXPCNT), getvar(GAIN), (int *) NewScreenAlign, mode);
```

with “mode” according to section 5.3.

The following program changes the image height to 1024 lines and allocates the corresponding memory:

```
#include <register.h>
#include <vcrt.h>
#include <sysvar.h>

main()
{
  U8 *start;

  print("test VC4002L linescan camera\n");
  tpict();
  print("ready\n");
  rs232rcv();
  print("allocating memory\n");

  start = (U8 *)byte_malloc(2049*1024);          /* allocate 2 MB of main memory + 1024 bytes
                                                for memory alignment*/

  setvar(DISP_START, ((I32)start + 1024) & ~0x3FF );
  setvar(CAPT_START, ((I32)start + 1024) & ~0x3FF );

  print("memory address: %08x\n", getvar(CAPT_START));
  print("changing vertical resolution\n");
  setvar(VWIDTH, 1024);

  print("ready\n");
}
```



Copy and paste this code into your program using Acrobat’s “text selection” tool.

6 Demo Program for different Capture Modes

```
/*
Program Description:
-----

This program shows the use of the 3 trigger modes of the VC4002L Linescan camera.

trigger mode 1: "SW trigger mode" - up to 11kHz
trigger mode 2: "HW trigger mode, variable exposure time" - up to 11kHz
trigger mode 3: "HW trigger mode, fixed exposure time" - up to about 5,4kHz

NOTE: - one capture request takes the number of lines specified in sysvar "VWIDTH" - per
default 512 lines!
- according to this, one tracking number refers to one image - comprising 512 lines per
default.
- scanning of one line is done in parallel with transferring the previous line into memory.
- the shutter speed set with "shutter" or shell command "Sh" refers to the line exposure time
(not the entire image).
- the minimum line exposure time is 90 microseconds, the maximum is 10479 microseconds.

*/
/*****/

#include <vcrt.h>
#include <vclib.h>
#include <macros.h>
#include <sysvar.h>

/*****/

void main(void)

{
int Run = 1, TrackNr, ms, ms1, ms2;

init_licence("XXXXXXXXXX"); // initialise your Licence code here

TRIGINP_POS(); /* image capture at rising trigger signal. */

tpict(); // or vmode(vmStill) required for Capture Mode 2 and 3

setvar(VWIDTH,100); // set image height to 100 lines - default is 512

TRIGOUT_EXP(); /* set trigger output to exposure controlled mode */
TRIGOUT_POS(); /* Trigout signal high during exposure - use pull up resistor between
trigout (grey) and 5V out (brown)!! */
```

```

while(Run)
{
    ms1 = getvar(MSEC);

/* Note: one Capture Request takes per default 512 lines - not only one! In HW trigger mode
this call requires 512 input signals to complete! */

TrackNr = capture_request(getvar(EXPCNT), getvar(GAIN), (int *)ScrGetCaptPage, 0);
/* now wait for external trigger */

    // trigger mode 1: "SW trigger mode - up to 11kHz:
        capture_request(getvar(EXPCNT), getvar(GAIN), (int *)ScrGetCaptPage, 0)
    // trigger mode 2: "HW trigger mode - up to 11kHz - shutter time depends on
trigger signal:
        capture_request(0, getvar(GAIN), (int *)ScrGetCaptPage,1)
    // trigger mode 3: "HW trigger mode - up to 5,4kHz - shutter time depends on
trigger signal:
        capture_request(getvar(EXPCNT), getvar(GAIN), (int *)ScrGetCaptPage,1)

/* checking that entire image - for instance 512 lines - are stored in memory before image
can be processed */

while(TrackNr > getvar(IMGREADY)); // Works with VC4002L - use
        while(wait(IMAGE_READY,100)!=1);" instead to free CPU time

//while(wait(IMAGE_READY,100)!=1); // Works with VC4002L - Advantage: CPU time available
        during wait, for instance to transfer images with a background task (img3par)

        //(while(!trdy()) //Does not work with VC4002L

        {
            if (kbhit())
            {
                print("kill capture\n");
                getchar();
                while(cancel_capture_rq()); // a capture request cannot be cancelt while
in mode 2 and 3 while an image is taken!
                Run = 0;
            }
        }
    ms2 = getvar(MSEC);
    ms = ms2 - ms1;
    if(ms<0) ms = ms+1000;
    print("Tracking No. = %d, Time = %d\n", TrackNr, ms);
}
}

/*****/

```

Appendix A: Block diagram VC4002L Line Scan Cameras

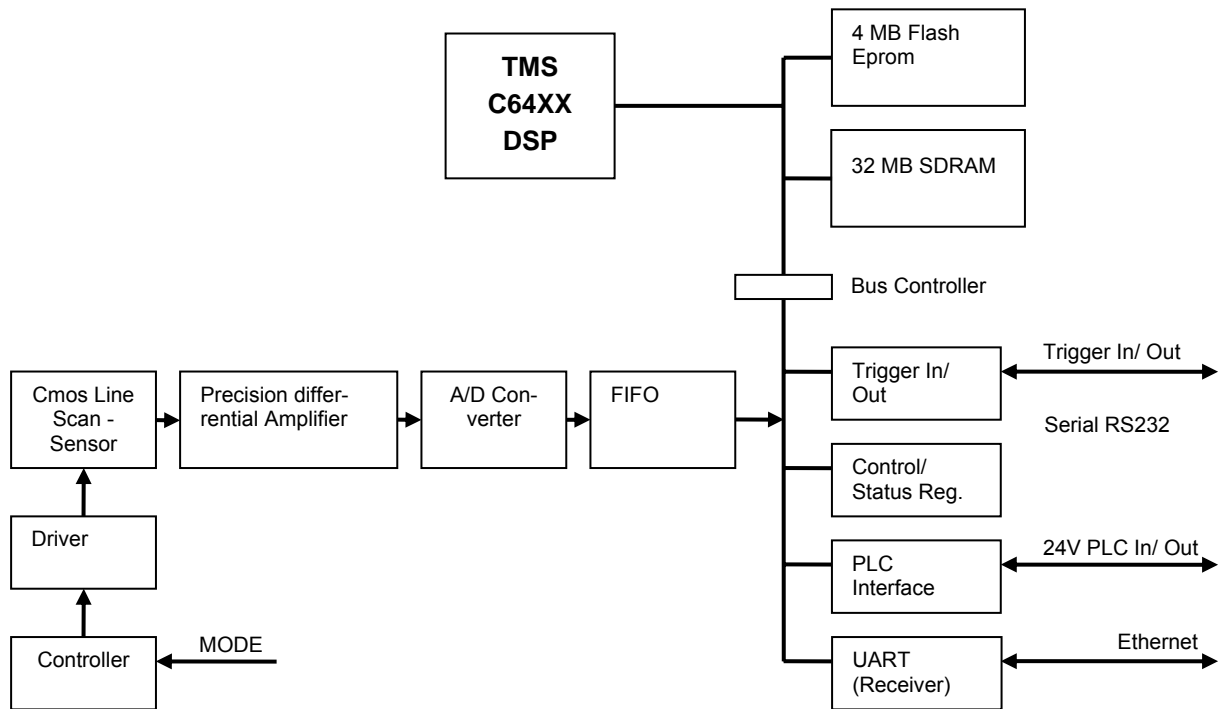

Appendix C: Overall Dimensions Housing VC4002L

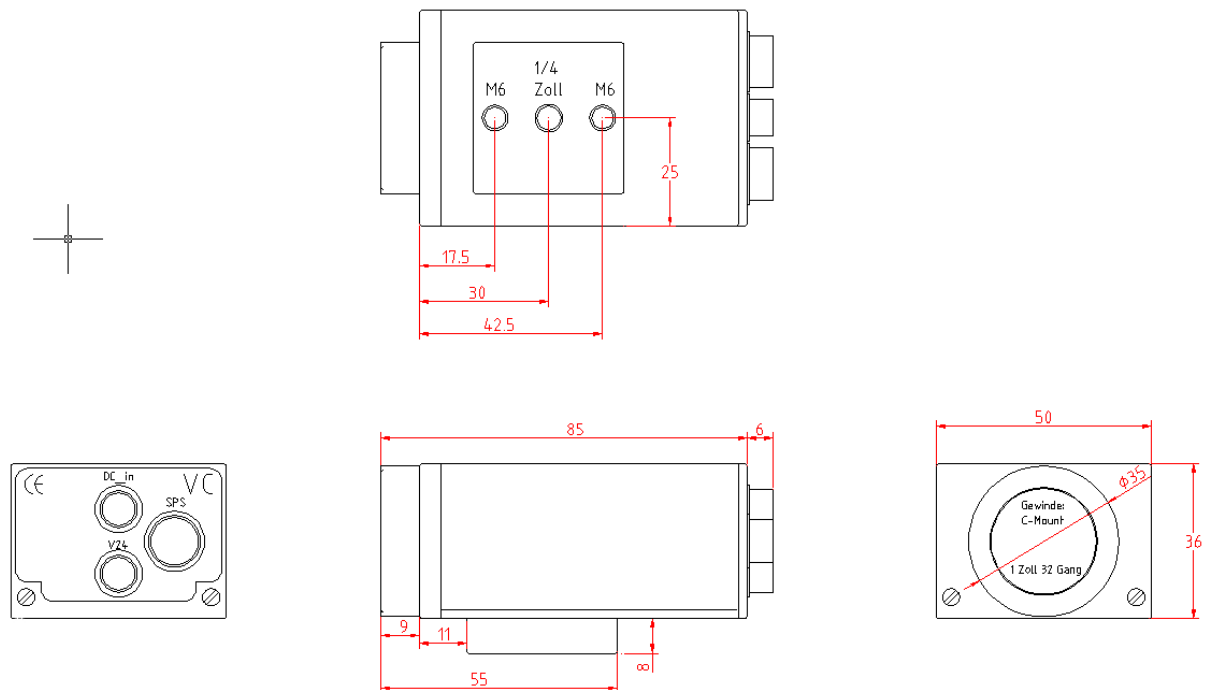

Appendix E: Drawing Camera Head VC4002L

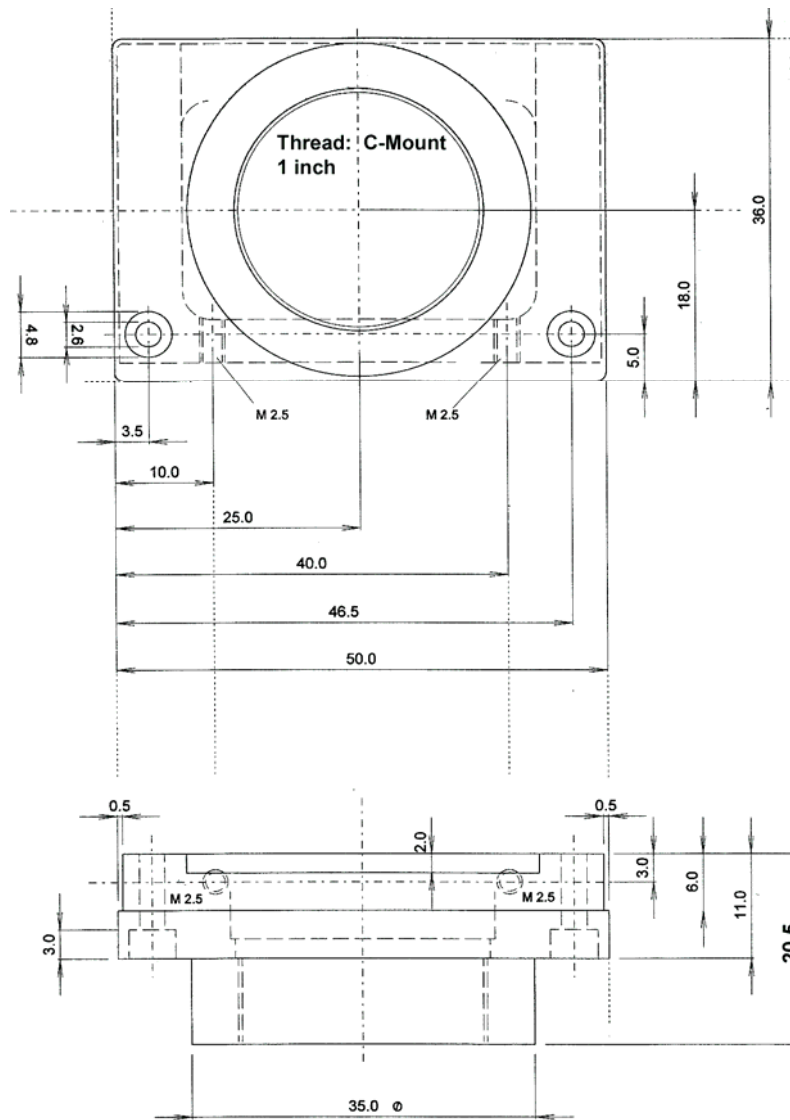

Appendix F: Mounting direction of the VC4002L

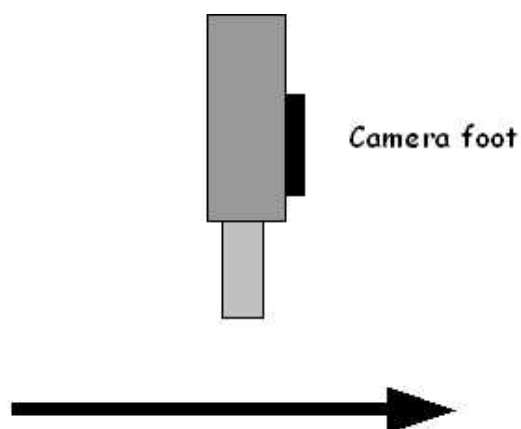

Mounted as shown above, produces an upright camera image with the direction of movement displayed.

Appendix G: Spectral Transmission of IR Filter

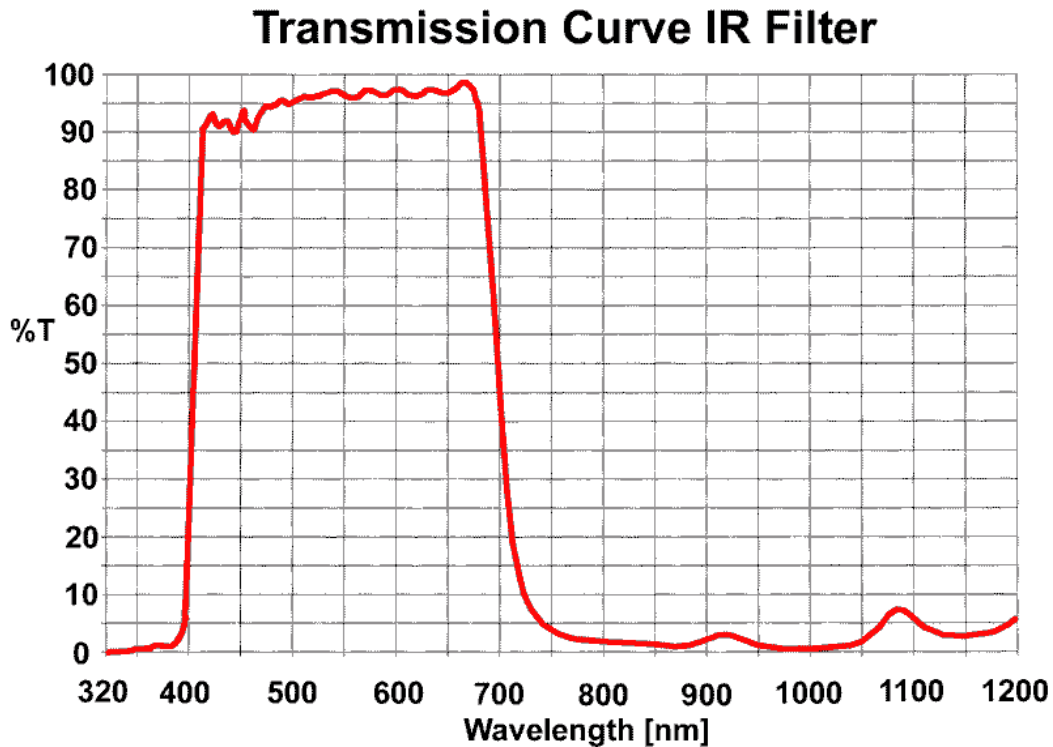
**Note:**

This IR cut filter is incorporated in every VC40XX camera. The IR filter can be removed if required without losing Vision Component's manufacturer's warranty. In this case, special care must be taken not to damage the CCD sensor.

If the camera is used without IR filter it is important to replace it by a clear glass filter of the same size. The C-mount flange distance from the CCD is accurately adjusted for the use of the IR filter – removing the filter decreases the length of the optical path and it may become impossible to focus some lenses to a larger working distance.



If the IR filter is not to be used, please order your camera with a clear glass filter or contact Vision Components for obtaining a glass filter.

The order numbers for the clear glass filter is: EK000624

The order number for the IR cut filter (standard) is: EK000625

INDEX

- accessories 6, 7, 12
- Accessories 13
 - Rail Mount Power Adapter 15
- Block diagram A
- Camera Head VC40XX B
- connector interfaces 6
- Dimensions A
- Electrical Specifications 10
- Ethernet Cable 13
- Ethernet Cables 13
- Ethernet Interface 7
- Housing VC40XX A
- Illumination Connector 6
- Illumination Interface 7
- Interfaces 6
- IR cut filter 15
- Keypad
 - Plug Assignment 8
- Keypad Interface 6, 8
- LAN / Ethernet Interface 7
- Order numbers 13
- pin assignments 6
- PLC
 - Trigger Input 10
 - Trigger Output 10
- Plug Assignment
 - Keypad 8
 - Overview 6
 - Trigger 8
- Power Adapter 15
 - Rail Mount 15
- Power and IO Connector 6
- power source 11
- Power Supply 6, 11, 12, 14
- Power Supply and IO Interface 11, 12, 14
- power supply interruption 11
- Programming 16
- Rail Mount Power Adapter 15
- References 2
- serial Cable 9
- Serial Cable 14
- Serial Interface 5, 19
- Specifications I
- Spectral Transmission C
- Trigger 6, 8, 9, 10, 13
 - Input 10
 - Output 10
 - Plug Assignment 8
- trigger output 10
- Trigger-/ V24 (RS232)-/ Keypad Interface 8
- TTL trigger input 10
- Y-Cable 9

It's no trick... it's a vision system

Visit the Vision Components site www.vision-components.com for further information and documentation and software downloads:

Web Site Menu Links	Content
Home	Latest News from VC
Our Company	VC Company Information
Contact Us	Distributor list / Enquiry forms
News	More News form VC
Products VC Hardware VCXX Camera Series VC20XX, VC4XXX Smart Cameras VCSBC Board Cameras VCM Camera Sensors VC Software VCRT Operating System VCLIB Image Processing Library Vision Components' Special Libraries 3rd Party Software	Product Overviews: including accessories listings with corresponding order numbers M200 Data Matrix Code Reader VCOCR Text Recognition Color Lib Overview of 3 rd Party software available for VC Smart Cameras
Support: Support News	Overview about latest features, manuals and SW updates
Knowledge Base / FAQ	Searchable HW and SW information database
Download Area Public Download Area (free access) Registered User DI Area (registration required) Customer Download Area (user- and software registration required)	Download of all: <ul style="list-style-type: none"> - Product brochures  - Camera Manuals - Programming Manuals - Software updates - Demo Codes - Programming Tutorials