

**It's no trick...  
it's a vision system**



**Vision  
Components**  
The Smart Camera People

# **VCSBC4018 / VCSBC4016 Manual**

Hardware and Software Manual for VCSBC4018 and  
VCSBC4016 Single Board Smart Cameras

Revision 3.1 July 2006  
Document name: VCSBC40XX.pdf  
© Vision Components GmbH Ettlingen,  
Germany

## Foreword and Disclaimer

This documentation has been prepared with most possible care. However Vision Components GmbH does not take any liability for possible errors. In the interest of progress, Vision Components GmbH reserves the right to perform technical changes without further notice.

Please notify [support@vision-components.com](mailto:support@vision-components.com) if you become aware of any errors in this manual or if a certain topic requires more detailed documentation.

This manual is intended for information of Vision Component's customers only. Any publication of this document or parts thereof requires written permission by Vision Components GmbH.

## Trademarks

Code Composer Studio and TMS320C6000, Windows XP, Total Commander, Tera Term, Motorola are registered Trademarks. All trademarks are the property of their respective owners.











## References

Since the VC40XX smart camera family employs a TI processor, the programming environment and functions for the VC20XX cameras can be used for this camera.

### Please also consult the following resources for further reference:

“[Support News](#)” for an overview of latest updates and support information

“[Knowledge Base / FAQ](#)” for a searchable data base of SW and HW questions / answers

Description	Title on Website	Download Area
 Quickstart Manual for VC camera set up and programming	 <a href="#">Getting Started VC Smart Cameras with TI DSP</a>	<a href="#">Public Download Area</a> ▶ <a href="#">Getting Started VC SDK Ti</a>
 Schnellstart VC – deutsche Version of „Getting Started VC“.	 <a href="#">Schnellstart VC Smart Kameras</a>	<a href="#">Customer Area</a> ▶ <a href="#">Getting Started VC20XX and VC40XX Cameras</a>
Introduction to VC Smart Camera programming	 <a href="#">Programming Tutorial for VC20XX and VC40XX Cameras</a>	<a href="#">Customer Area</a> ▶ <a href="#">Getting Started VC20XX and VC40XX Cameras</a>
Demo programs and sample code used in the Programming Tutorial	 <a href="#">Tutorial_Code</a>	<a href="#">Customer Area</a> ▶ <a href="#">Getting Started VC20XX and VC40XX Cameras</a>
VC40XX Hardware Manual	 <a href="#">VC40XX Smart Cameras Hardware Documentation</a>	<a href="#">Public Download Area</a> ▶ <a href="#">Hardware Documentation VC Smart Cameras</a>
VCRT Operation System Functions Manual	 <a href="#">VCRT 5.0 Software Manual</a>	<a href="#">Registered User Area</a> ▶ <a href="#">Software documentation VC Smart Cameras</a>
VCRT Operation System TCP/IP Functions Manual	 <a href="#">VCRT 5.0 TCP/IP Manual</a>	<a href="#">Registered User Area</a> ▶ <a href="#">Software documentation VC Smart Cameras</a>
VCLIB 2.0 /3.0 Image Processing Library Manual	 <a href="#">VCLIB 2.0/ 3.0 Software Manual</a>	<a href="#">Registered User Area</a> ▶ <a href="#">Software documentation VC Smart Cameras</a>



- The Light bulb highlights hints and ideas that may be helpful for a development.



- This warning sign alerts of possible pitfalls to avoid. Please pay careful attention to sections marked with this sign.

**Author:** Peter Neuhaus, VC Support, <mailto:support@vision-comp.com>

## Table of Contents

<b>1 General Information</b>	<b>4</b>
<b>2 Basic Structure</b>	<b>5</b>
<b>3 Technical Specifications VCSBC4018</b>	<b>6</b>
<b>4 Technical Specifications VCSBC4016</b>	<b>7</b>
<b>5 Camera Interfaces</b>	<b>8</b>
5.1.1 Pin Assignments J1 camera socket	9
5.1.2 Electrical specifications J1 camera socket	9
5.1.3 Available accessories for this J1 camera socket	9
5.2 J2: Expansion Port / Trigger Interface	10
5.2.1 Pin Assignments J2 camera socket	10
5.2.2 Electrical specifications J2 camera socket	11
5.2.3 Matching connector and cable for J2 camera socket	13
5.3 J3: Power Supply and IO Interface	14
5.3.1 Pin Assignments J3 camera socket	14
5.3.2 Electrical specifications digital IO s J3 interface	14
5.3.3 Electrical specifications of the VCSBC40XX Power Supply J3 interface	16
5.3.4 Matching connector and cable for J3 camera socket	17
5.4 J4: Ethernet Interface	18
5.4.1 Pin Assignments J4 camera socket	18
5.4.2 Electrical specifications J4 camera interface	18
5.4.3 Matching connector and cable for J4 camera socket	19
5.5 J6: Emulator Interface	20
5.5.1 Pin Assignments J6 camera socket	20
5.5.2 Electrical specifications J6 camera socket	20
5.5.3 Matching connector and cable for J6 camera socket	20
<b>6 Accessories</b>	<b>21</b>
<b>7 Programming VCSBC40XX Cameras</b>	<b>23</b>
7.1 Special Software requirements for the VCSBC40XX	23
7.2 Ethernet Communication	24
7.3 Using FTP with the VCSBC40XX	24
7.4 Preventing Autoexec Execution / IP number reset	24
7.4.1 Resetting the Camera with help of the VCnet Recovery Tool	25
7.5 Special VCRT functions for programming VCSBC40XX cameras	26
7.5.1 Trigger Functions	26
7.5.2 Controlling the Illumination Interface J1	27
7.5.3 Controlling the TTL IOs on socket J2	27
<b>Appendix A: Block diagram VCSBC40XX Smart Camera</b>	<b>A</b>
<b>Appendix B: New VCRT Functions VCSBC40XX Smart Camera</b>	<b>A</b>
<b>Appendix C: Overall Dimensions VCSBC40XX</b>	<b>B</b>
<b>Appendix D: Drawing Circuit Board VCSBC40XX</b>	<b>B</b>
<b>Appendix E: Drawing Camera Head VCSBC40XX</b>	<b>B</b>
<b>Appendix E: Drawing Camera Head VCSBC40XX</b>	<b>C</b>
<b>Appendix F: Spectral Transmission of IR Filter</b>	<b>D</b>
<b>Index</b>	Fehler! Textmarke nicht definiert.

# 1 General Information



**VCSBC40XX Single Board Camera with detached head**



**VCSBC40XX Single Board Camera with mounted sensor board (standard delivery)<sup>1</sup>**

The **VCSBC4018** and **VCSBC4016** represent the fastest single board Smart Cameras available – designed for demanding OEM applications. The computational power of 3200 MIPS on a 60 by 80mm circuit board is equal to a 2.6 GHz Pentium PC. The VCSBC40XX includes 32 MB DRAM and a 4 MB Flash EPROM for non-volatile program and data storage. The VCSBC4018 can acquire full frame VGA images at 32 frames per second (progressive scan). The VCSBC4016 features a maximum frame rate of 16.7 at 1024x768 pixel resolution.

Like with all VC Smart Cameras with Texas Instruments DSP, the operation system VCRT allows multi-tasking. This means for instance that user interface commands can execute in parallel without stopping the inspection process. It is also possible to transfer live images via TCP/IP using a background task.

Whereas a standard progressive scan camera gets a trigger, starts exposure and then reads out the pixel data, the VCSBC40XX has optimized the image acquisition process so that exposure, image transfer into memory and image processing can be done in parallel. This means if exposure time and image processing time is not longer than the transfer time, the full frame rate can be maintained.

The VCSBC40XX cameras offer an inexpensive entrance into the world of the high performance intelligent cameras. It has a video output onto a PC via 100MBit Ethernet interface, a high speed trigger input and output, 12-24 V digital IOs, additional TTL IOs and an illumination controller.

---

<sup>1</sup> Note: Separate order of C-mount or 12mm lens holder required – see section 6 for details.

## 2 Basic Structure

The image is formed by a high-resolution progressive scan CCD sensor. One channel of video input is digitized. The image is stored in SDRAM memory using one of the 64 DMA channels (EDMA).

Unlike most other Vision Component Smart Cameras, the VCSBC40XX does not have a direct video output. However if monitoring of the camera image is required, this can be done by downloading via Fast Ethernet port to PC and display on screen (see **"Image Transfer" demo software under "Support -> Customer Area -> Software Utilities"**).

The TMS320C64xx DSP is one of the fastest 32bit DSPs. It features a RISC-like instruction set, up to 8 instructions can be executed in parallel, two L1 cache memories (16 Kbytes each) and a 128 Kbytes L2 cache on chip. Its high speed 64-channel DMA controller gives additional performance. The DSP uses fast external SDRAM as main memory. A flash EPROM provides non-volatile memory.

[See Appendix A: Block diagram VCSBC40XX Smart Camera](#)

### 3 Technical Specifications VCSBC4018

Component / Feature	Specification
CCD Sensor:	1/3" SONY ICX424AL - also available with color sensor (Bayer Filter)
eff. no. of pixels:	640(H) x 480(V)
Pixel size:	7.4(H) x 7.4(V) $\mu\text{m}$
Chip size:	5.79(H) x 4.89(V) mm
High-speed shutter:	36.2 <sup>2</sup> , 98.6, 161 microseconds, increasing with steps of 62.4 microseconds (full-frame shutter)
Low-speed shutter:	up to 2 sec. adjustable integration time
Integration:	full-frame
Picture taking:	program-controlled, trigger controlled (interrupt); full-frame / 32 frames per second, external high speed trigger
Clamping:	zero offset digital clamping
A/D conversion:	12.5 MHz / 10 bit, only the 8 most significant bits used for grey values
Input LUT	none
Image Display	Via 100 Mbit Ethernet onto PC
Processor:	Texas Instruments TMS320C64XX signal processor 400 MHz, 3200MIPS
RAM:	32 Mbytes SDRAM (synchronous dynamic RAM)
Memory capacity:	Up to 100 full-size images in format 640x480
Flash EPROM:	4 Mbytes flash EPROM (nonvolatile memory) for programs and data, in-system programmable, 3 MB available to user
MMC:	Not available
Process interface:	2 inputs / 4 outputs, outputs 4x400 mA
Additional LVTTTL IOs:	4 Inputs, 4 Outputs, I2C Clock and Data signals
Illumination Controller:	Illumination Enable LVTT output, Duration / Boost LVTTTL output
Ethernet interface:	100 Mbit
CE certification:	No CE Certification from Vision Components as the OEM customer is required to certify entire system (including housing, cabling, etc.).
Storage Conditions	Temperature: -20 to 60 deg C, Max. humidity: 90%, non condensing.
Operating Conditions	Temperature: 0... +55 deg C (heat sink temperature), Max. humidity: 80%, non condensing.
Power Supply	12V... 24V
Power Consumption	$\approx$ 2.4W (current drawn from PLC outputs or onboard 3.3 V signal additional)

<sup>2</sup> From CPLD file version 4 – check with shell command “ver”.

## 4 Technical Specifications VCSBC4016

Component / Feature	Specification
CCD Sensor:	1/3" SONY ICX204 AL - also available with color sensor (Bayer Filter)
eff. no. of pixels:	1024 (H) x 768 (V)
Pixel size:	4.65 (H) x 4.56 (H) $\mu\text{m}$
Chip size:	5.80(H) x 4.92(V) mm
High-speed shutter:	From 46.7, 122.9, 199.1 microseconds, increasing with steps of 76.2 microseconds (full-frame shutter)
Low-speed shutter:	up to 2 sec. adjustable integration time
Integration:	full-frame
Picture taking:	program-controlled, trigger controlled (interrupt); full-frame / 16.7 frames per second, external high speed trigger
Clamping:	zero offset digital clamping
A/D conversion:	16.7 MHz / 10 bit, only the 8 most significant bits used for grey values
Input LUT	none
Image Display	Via 100 Mbit Ethernet onto PC
Processor:	Texas Instruments TMS320C64XX signal processor 400 MHz, 3200MIPS
RAM:	32 Mbytes SDRAM (synchronous dynamic RAM)
Memory capacity:	Up to 37 full-size images in format 1024x768
Flash EPROM:	4 Mbytes flash EPROM (nonvolatile memory) for programs and data, in-system programmable, 3 MB available to user
MMC:	Not available
Process interface:	2 inputs / 4 outputs, outputs 4x400 mA
Additional LVTTTL IOs:	4 Inputs, 4 Outputs, I2C Clock and Data signals
Illumination Controller:	Illumination Enable LVTT output, Duration / Boost LVTTTL output
Ethernet interface:	100 Mbit
CE certification:	No CE Certification from Vision Components as the OEM customer is required to certify entire system (including housing, cabling, etc.).
Storage Conditions	Temperature: -20 to 60 deg C, Max. humidity: 90%, non condensing.
Operating Conditions	Temperature: 0... +55 deg C (heat sink temperature), Max. humidity: 80%, non condensing.
Power Supply	12V... 24V
Power Consumption	$\approx$ 2.4W (current drawn from PLC outputs or onboard 3.3 V signal additional)

## 5 Camera Interfaces

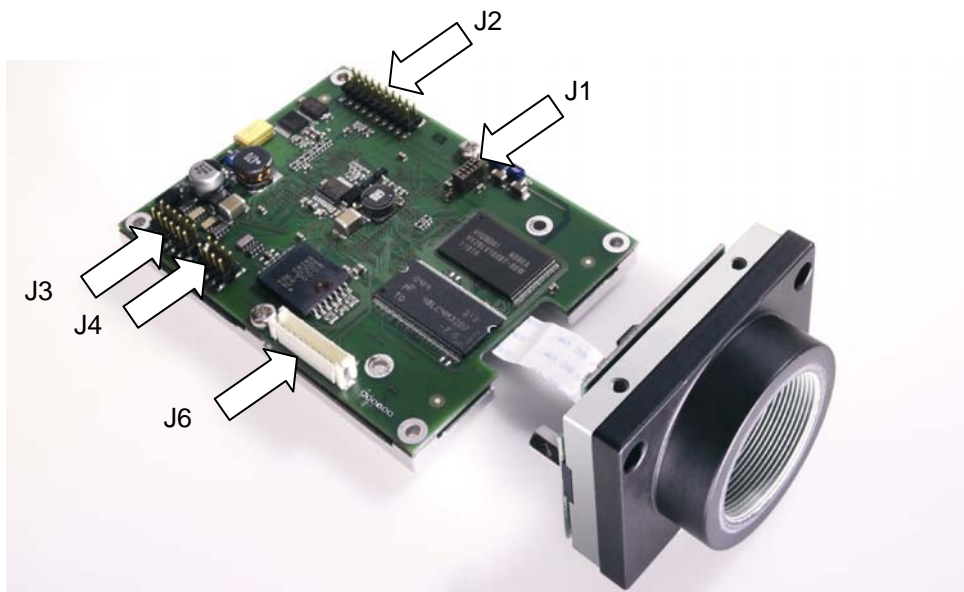

The VCSBC40XX camera board incorporates the following connector interfaces:

- J 1 : Illumination Connector
- J 2: Expansion Port Connector
- J 3: VCSBC40XX/ VCSBC50 Power and IO Connector<sup>3</sup>
- J 4: Ethernet Connector
- J 6: Emulator Connector

The pin assignments, electrical specifications as well as available accessories are shown for each interface connector in the following sections.

Please refer to Please refer to “Appendix D: Drawing Circuit Board VCSBC40XX” for the pin 1 orientation of the camera board sockets.

---

<sup>3</sup> Deviating from the image, the VCSBC4018 is now shipped with a wall plug with center polarization slot as shown in section 5.3.1.

J1 : Illumination Interface

### Pin Locations

Blank side of ribbon cable

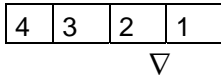

Isolated side of ribbon cable

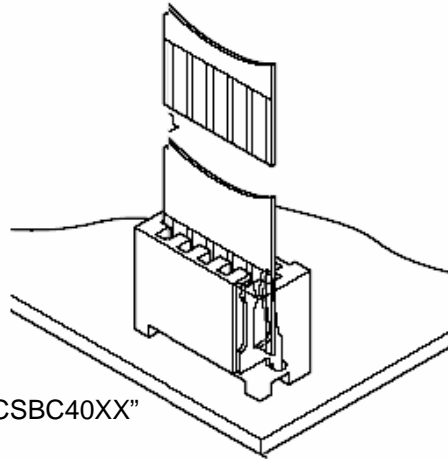

Please refer to “Appendix D: Drawing Circuit Board VCSBC40XX” for the pin 1 orientation on the camera board socket.

#### 5.1.1 Pin Assignments J1 camera socket

Pin	Signal
1	GND
2	+3.3V out, max current 100mA
3	Illumination Enable, LVTTTL
4	Duration / Boost LVTTTL

Please refer to “Appendix D: Drawing Circuit Board VCSBC40XX” for the pin 1 location.

#### 5.1.2 Electrical specifications J1 camera socket

- Output Voltage on Pin 2 is regulated (+3.3V ±5%). Maximum current 100 mA.
- Outputs Pin 3 and 4 are Cmos low voltage TTL signals, intended to switch the illumination.

In exposure controlled mode (default) the “Illumination Enable” output high during exposure. Trig\_out, pin 16, connector J2 is high at the same time, so controlling an external light source can be done using either output.



**Caution:** Do not reverse the flat cable connected to this socket!

#### 5.1.3 Available accessories for this J1 camera socket

Part number of the J1 socket: 04FM-1.0BP-TF , manufactured by JST ( [www.jst.com](http://www.jst.com) )

The matching flat cable (at 38mm length) for this connector can be ordered from Vision Components:

Order number: EK000377

## 5.2 J2: Expansion Port / Trigger Interface

Note that the LVTTTL IOs are very sensitive. Only use driving electronics suitable for LVTTTL IO's!



### 5.2.1 Pin Assignments J2 camera socket

Pin Number	Signal
1	Q00
2	Q01
3	Q02
4	Q03
5	GND
6	GND
7	I00
8	I01
9	I02
10	I03
11	I2C_Clock
12	I2C_Data
13	NC
14	NC
15	Trig_in
16	Trig_out
17	NC
18	NC
19	Vcc (3.3V)
20	GND

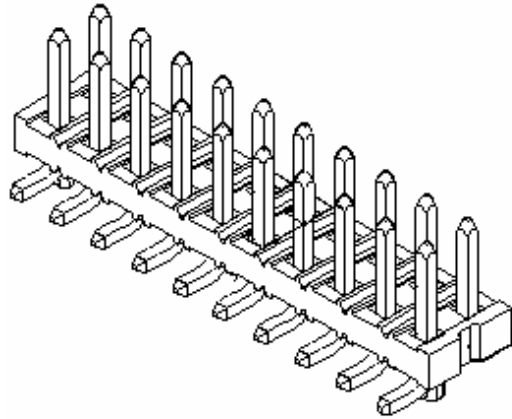

#### Pin Locations

2	4	6	8	10	12	14	16	18	20
1	3	5	7	9	11	13	15	17	19



Please refer to “Appendix D: Drawing Circuit Board VCSBC40XX” for the pin 1 orientation on the camera board socket.

Q00 – Q03	digital LVTTTL outputs
I00 – I03:	Digital LVTTTL input (without pull-up resistor)
Vcc	3.3V board main voltage, I <sub>max</sub> = 100mA
I2C_Clock and I2C_Data	I2C serial Bus Interface for additional peripherals (Refer to the Texas Instruments documentation <sup>4</sup> for further details)
Trig_in and Trig_out	Trig_in and Trig_out – are not opto isolated, so special care must be taken or Isolation has to be done externally!

In exposure controlled mode (default) the trigger output is high during exposure.

<sup>4</sup> “TMS320C6000 DSP Inter-Integrated Circuit (I2C) Module Reference Guide”, Literature Number: SPRU175A, Oct. 2002

### 5.2.2 Electrical specifications J2 camera socket

All Signals are Low Level TTL (3.3V), not opto isolated.

The electrical specifications given for the trigger input and output are also valid for the remaining LVTTTL IOs.

The following Signals have a 4k7 pull up resistor on board:

- I2C\_Clock
- I2C\_Data
- Trig\_in

#### Trigger IO Specifications:

The board features a dedicated fast TTL trigger input (for use as image capture trigger) and a fast TTL trigger output (as strobe-light trigger). Since both signals are fast at a very low noise margin, it is recommended to keep the cable as short as possible. Use twisted pair or even coaxial cable for this purpose. The trigger input assures a constant image capture delay without jitter.

#### Electrical Specification of trigger input <sup>5</sup>:

input voltage: Signal LOW	-0.3V – 0.8V (LVTTTL)
Input voltage: Signal HIGH	2V – 3.9V (LVTTTL)
input current:	N/A
limiting resistor:	4k7 pull up
reverse voltage protection:	none
switching delay:	interrupt latency only

Image trigger on rising or falling input signal works as before – see section 7.5.1 for details.



**The trigger input and output are very sensitive and not galvanically separated. Opto isolation of the driving circuit is therefore strongly recommended. The following page shows suitable circuits for trigger input and output.**

Please note that input and output are not protected against over current. The output is neither protected against short circuit nor reverse voltage spikes from inductive loads.



Use the VC4018 or VC4016 cameras if you can not provide a suitable trigger input driving circuit. These cameras include the same hardware as the VCSBC4018 / -16, but opto isolation of the trigger input and output is already included.

<sup>5</sup> The electrical specifications given for the trigger input and output are also valid for the remaining LVTTTL IOs.

**Recommended driving circuit for the trigger input:**

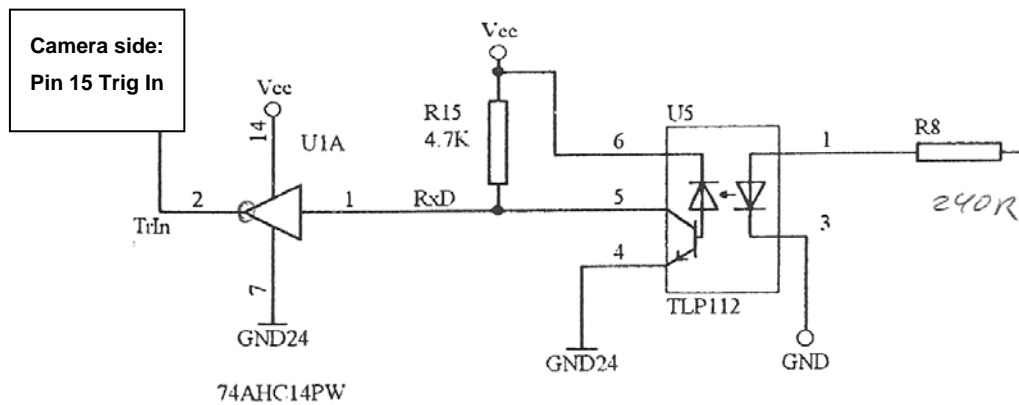

**Electrical Specification of trigger output<sup>6</sup>:**

output voltage signal LOW:	0.4 V with 8mA output current 0.2 V with 1mA output current
output voltage signal HIGH:	2.9 V with 8mA output current 3.1 V with 1mA output current max. 3 V LVTTTL
Maximum output current:	max. 8 mA
pull-up resistor:	none, LVTTTL push-pull output

Caution: Place the connectors at the correct position – not reversed or shifted. The position of Pin 1 for each connector is marked in [Appendix D: Drawing Circuit Board VCSC40XX](#).

**Recommended circuit for trigger output:**

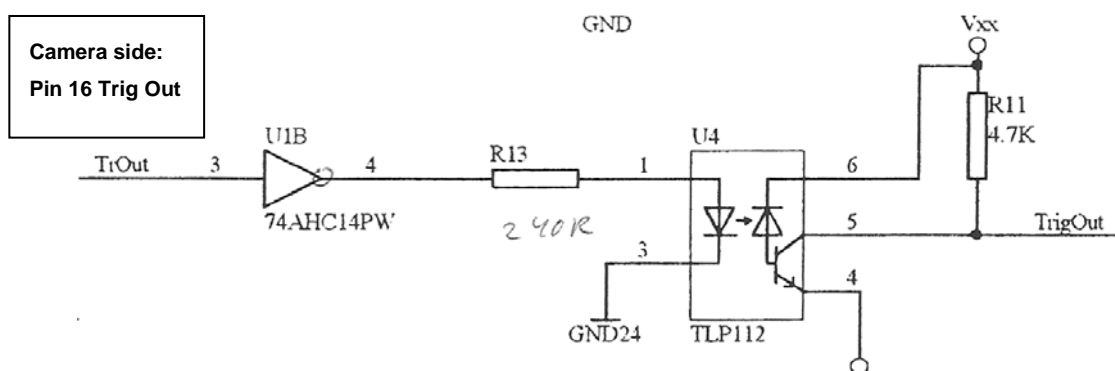

<sup>6</sup> The electrical specifications given for the trigger input and output are also valid for the remaining LVTTTL IOs.

**External Trigger Timing (VCSBC4018):**

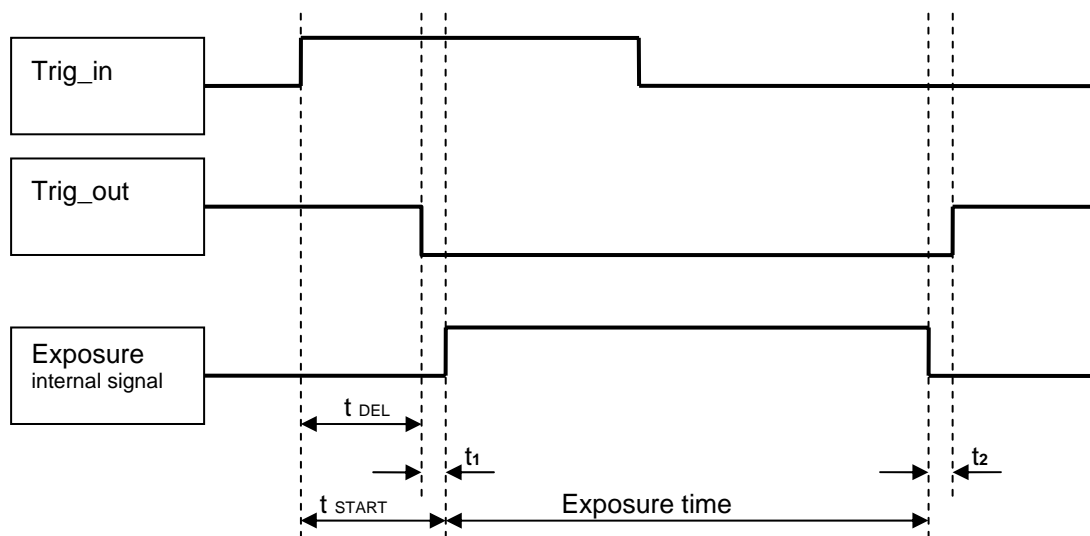

Signal	Description	Value / Tolerance
t <sub>DEL</sub>	Delay from external trigger input to trigger output	62.6 μsec ±100 nsec
t <sub>START</sub>	Delay from external trigger input to start of exposure	70 μsec ±100 nsec
Δt <sub>DEL</sub> and Δt <sub>START</sub>	Jitter	Less than 10nsec
t <sub>1</sub>	Time form the leading edge of the trigger output signal to the trailing edge of the exposure signal	7.4 μsec ±100 nsec
t <sub>2</sub>	Time from leading edge of the exposure signal to the trailing edge of the trig_out signal	19 μsec ±100 nsec

**5.2.3 Matching connector and cable for J2 camera socket**

The socket J2 has the following part number: 8775967-2050, manufacturer Molex ([www.molex.com](http://www.molex.com))  
 The matching connector has the following part number: 51110-2050

Vision Components does not currently manufacture a cable for this connector. Please order the matching connector from the manufacturer Molex.

Alternatively an additional 12 pin Power Supply /PLC and a 8 pin Ethernet cable (Cable set for VCSBC4018, VK000229 see section 6) can be used next to each other to cover all contacts. Since only pin 1,2,5 and 6 of the 8 pin Ethernet connector are connected, place these two plugs on the J2 sockets as shown below:

Pin 1-12 use J3 cable      Pin 13-20 use J4 cable (pin number of connector given here)

2	4	6	8	10	12	NC	5	NC	1
1	3	5	7	9	11	NC	6	NC	2

▽

Compare with socket pin numbers in [5.2.1](#)

### 5.3 J3: Power Supply and IO Interface

The J3 connector includes the camera power supply and the digital IOs.

#### 5.3.1 Pin Assignments J3 camera socket

Pin Number	Signal
1	Out0
2	Power (12-24V)
3	Out1
4	Power GND
5	Out2
6	NC
7	Out3
8	GND
9	In0
10	NC
11	In1
12	GND

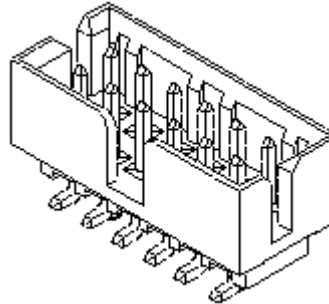

J3 Standard  
VCSBC40XX socket:  
Molex: 8783212-20 with  
center polarization slot  
(different to camera  
images in this manual!)

#### Pin Locations

2	4	6	8	10	12
1	3	5	7	9	11



Please refer to “Appendix D: Drawing Circuit Board VCSBC40XX” for the pin 1 orientation on the camera board socket.

#### 5.3.2 Electrical specifications digital IO s J3 interface

The camera has two PLC compatible inputs and four PLC compatible high-current outputs for controlling machines and processes.



Inputs and outputs are not galvanically decoupled from the supply voltage.

A protective diode ensures, the poles of the supply voltage from the power supply of the PLC can not be swapped.

The outputs are floating when low - pull down resistor required.

### Input Signals IO interface

Nominal voltage:	12 – 24 V
Absolute maximum voltage:	voltages greater than 40 V can destroy the inputs
Type:	Circuit GND directly connected
Input current:	1 mA @ 24V
Threshold value:	10 V
Internal signal delay:	- No delay for direct IO access - 10ms delay for DSP polling

The PLC-compatible inputs (24-V level, the positive signal is connected) include input protection circuits. A minimum voltage of 10V is required to reliably sense a logic high signal.

### Output Signals IO Interface

Operating voltage:	external source 12 – 24 V
Absolute maximum voltage:	voltages greater than 40 V can destroy the outputs
Type:	Circuit GND directly connected
Switching voltage:	positive switching (PNP)
Current:	max. 400 mA per output
Absolute maximum current:	total currents greater than 1000 mA can destroy plugs and cables Always consider the total sum of all output currents
Total current / over current output protection	Yes – if $\Sigma i_{out} > 1A \rightarrow$ all Outputs are switched off – Retry after 3 seconds
Switching power:	max. 9.6 W (24 V * 400 mA) per output
Reverse voltage protection	yes, for external voltage
Protection against inductive loads:	yes
Resistance when switched on:	0.2 - 0.8 Ohm
Short circuit protection:	full protection

The PLC outputs feature a highly integrated MOSFET, high-side switch with built-in protection . It is possible to switch inductive or capacitive loads. The protective feature of the outputs will produce pulses on the outputs, if the limiting values are exceeded.

Output drivers feature short circuit end thermal overload protection

For additional protection of the output drivers, the I/O processor monitors the total PLC current, and switches off all outputs if the maximum threshold value is exceeded.

### 5.3.3 Electrical specifications of the VCSBC40XX Power Supply J3 interface

Nominal Voltage:	12V – 24V
Nominal Power Consumption <sup>7</sup> :	2.4W
Minimum operational voltage (including ripple):	9V
Minimum Operating voltage and corresponding current:	12V 200mA <sup>8</sup>
Maximum Operating voltage and corresponding current:	24V 100mA <sup>3</sup>
Maximum operational Voltage (including ripple):	30V

Power must be connected to the 12 pin J3 I/O connector.

Camera power is regulated and galvanically separated inside the camera, so only an unregulated power source of 12 V to 24V is required. The camera is, however, very sensitive to power supply interruption. Please make sure, that the voltage never exceeds the limits of < 9V, > 30V even for a short period of time. In case of trouble it is recommended to backup the power supply by a capacitor or a battery large enough to prevent power interruptions.

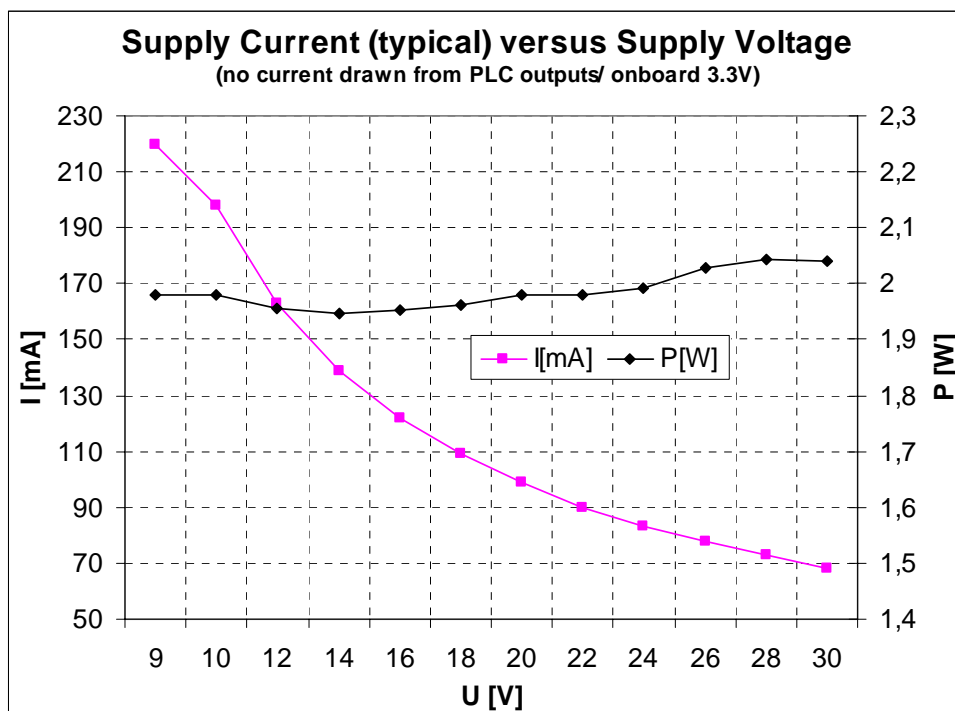

<sup>7</sup> Maximum power consumption without using the PLC output or onboard 3.3V supply.

<sup>8</sup> Current drawn for PLC outputs and the 3.3V on board signal needs to be added to these figures.

### 5.3.4 Matching connector and cable for J3 camera socket

J2 Standard VCSBC40XX socket: Molex: 8783212-20 with center polarization slot (see above)

The wall socket with polarization slot has been used for this camera in order to avoid camera damage caused by shifted or reversed plug connections.

The standard VCSBC50 cable can be used to prevent shifted plug mounting:

#### Color code VCSBC50/ VCSBC40XX Power / PLC Cable VC000173:

Pin Number	Signal	
1	Out0	Blue
2	Power (24V)	Red
3	Out1	purple
4	Power GND	Black
5	Out2	Grey/ red
6	NC	Green
7	Out3	Blue/ red
8	GND	Yellow
9	In0	grey
10	NC	white
11	In1	pink
12	GND	brown

#### Pin arrangement (looking down on circuit board socket):

2	4	6	8	10	12
1	3	5	7	9	11

▽

Please refer to “Appendix D: Drawing Circuit Board VCSBC40XX” for the pin 1 orientation on the camera board socket.

For additional safety against reversed connections (using the with center polarization slot of the socket), please order one of the following connectors from the manufacturer Molex ([www.molex.com](http://www.molex.com)):

Part numbers: 87568-1263, 87568-1264, 87568-1273, 87568-1274

## 5.4 J4: Ethernet Interface

### 5.4.1 Pin Assignments J4 camera socket

Pin Number	Signal
1	TXD+
2	TXD-
3	GND
4	GND
5	RXD+
6	RXD-
7	GND
8	GND

#### Pin locations:

2	4	6	8
1	3	5	7



Please refer to “Appendix D: Drawing Circuit Board VCSBC40XX” for the pin 1 orientation on the camera board socket.

### 5.4.2 Electrical specifications J4 camera interface

The Ethernet interface is decoupled from the rest of the circuit with a 1.5kV insulation transformer. For all connection specifications refer to the Ethernet standard.

### 5.4.3 Matching connector and cable for J4 camera socket

Socket J4 on circuit board: Part number: 87759-0850, manufacturer: Molex  
 Matching connector: Part number: 51110-0850, manufacturer: Molex

There are two different cables now available for the J4 Ethernet interface:

#### 1. OEM cable:

**VK000206** – Molex connector 51110-0850 with 4 cables attached, 0.5m long, no connector on other end. This cable is also part of the “cable set” VK000229 (see section 6 Accessories).

#### 2. Testing cable:

**VK000251** - Molex connector 51110-0850 with 4 cables and confectioned with RJ45 connector on other end, 2.5m long.

#### Pin assignment OEM Ethernet cable VK000206:

PIN (J4)	Signal	Cable Color
1	TXD+	blue
2	TXD-	red
3	GND	N/C
4	GND	N/C
5	RXD+	Pink / black
6	RXD-	green
7	GND	N/C
8	GND	N/C

#### Pin assignment testing Ethernet cable VK000251:

PIN (J4)	Cable Color (J4)	Signal	Cable Color (RJ45)	PIN (RJ45)
1	blue	TXD+	Orange/ white	1
2	red	TXD-	Orange	2
3	N/C	GND	N/C	
4	N/C	GND	N/C	
5	Pink / black	RXD+	Green/ white	3
6	green	RXD-	Green	6
7	N/C	GND	N/C	
8	N/C	GND	N/C	

The change of core colors results from connecting two cables (VK000206 and a standard Ethernet cat 5 cable).

## 5.5 J6: Emulator Interface

### 5.5.1 Pin Assignments J6 camera socket

Pin Number	Signal
1	Vcc (3.3V)
2	GND
3	NC
4	EMU0
5	EMU1
6	TRST
7	TCK
8	TDI
9	TD0
10	TMS

Pin Number	Signal	Color
1	TMS	Black
2	TRST	Pink
3	TDI	Purple
4	NC	
5	Vcc(3.3V)	White
6	NC	
7	TD0	Red
8	NC	
9	TCK	Blue
10	NC	
11	TCK	Blue
12	NC	
13	EMU0	Yellow
14	EMU1	Grey

#### Pin Locations J6 Socket:

10	9	8	7	6	5	4	3	2	1
----	---	---	---	---	---	---	---	---	---



Please refer to “Appendix D: Drawing Circuit Board VCSBC40XX” for the pin 1 orientation on the camera board socket.

#### Pin Locations JTAG connector (Molex 8775967-2050):



1	3	5	7	9	11	13
2	4	6	8	10	12	14

### 5.5.2 Electrical specifications J6 camera socket

This information is available on request.

### 5.5.3 Matching connector and cable for J6 camera socket

VC provides an adaptor cable that connects the J6 Emulator socket with the Jtag Emulator connector.

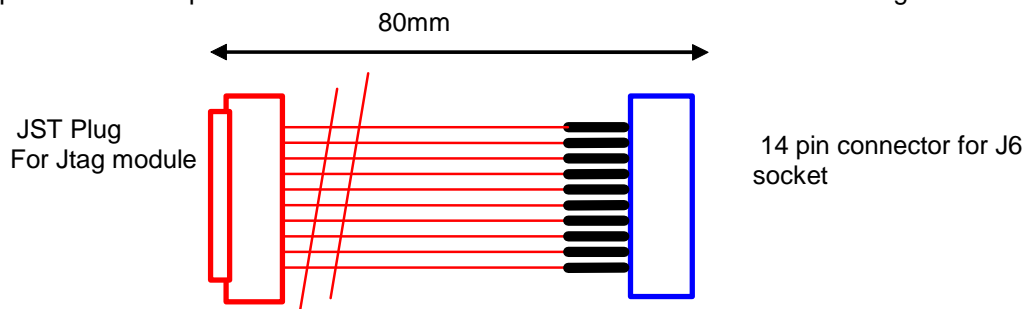

Order Number for the J6 /JTAG Adaptor cable from Vision Components: **VK000248**

## 6 Accessories

For interface cables and connectors available also consult the corresponding section in chapter 4 of this manual.



The VCSBC40XX can be used with 12mm threaded micro lenses or C-mount lens holder. Due to the different options these **lens holders have to be ordered separately** to the camera. If ordered together, VC ships the camera fully assembled.



The **C-mount flange distance can then be accurately adjusted at no additional charge**. Please remove the protective foil on the CCD in case the camera has been ordered and delivered without lens holder!

### Camera and Lens holder order numbers:

Product / Service description	Order Number
VCSBC4018 Single Board Smart Camera <b>without</b> lens holder, b/w CCD	VK000208
VCSBC4018 Single Board Smart Camera <b>without</b> lens holder, Bayer CCD	VK000271
VCSBC4016 Single Board Smart Camera <b>without</b> lens holder, b/w CCD	VK000255
VCSBC4016 Single Board Smart Camera <b>without</b> lens holder, Bayer CCD	VK000270
Lens holder C Mount incl. adjustment (IR Filter EK000625 included)	VK000087
Lens holder 12mm (Clear glass window EK000624 included)	VK000091

**Further accessories available for the VCSBC40XX:**

<b>Product description</b>	<b>Order Number</b>
Power adapter for rail mounting, Input Voltage 100 – 240VAC 50/60 Hz Output Voltage DC 24V +/-5%, max. 300 mA (7.5 W) Equipped with connecting clamps for AC input and 24V output, CE cert.	VK000036
Cable for illumination Interface J1 (flat ribbon, length = 38mm)	EK000377
Cable for Expansion Port J2 (use cable set VK000229 see section 0) It is recommended to manufacture matching circuit board	VK000229
Power Supply and IO Interface cable for J3	VK000173
Ethernet OEM Cable for J4 (0.5m length, 4 single cores)	VK000206
Ethernet testing Cable for J4 (2.5m length, other end with RJ45 connector)	VK000251
Emulator Adaptor Cable for J6	VK000248
Cable set for VCSBC4018 (contains VK000206 and VK000173)	VK000229
Cable for Emulator interface J6	VK000086
Flex cables for detached Camera Head mounting:	30mm x 20 <sup>1</sup> EK000321
	80mm x 20 core EK000322
<sup>1</sup> The 30mm flex cable is part of standard delivery.	200mm x 20 core EK000629
Clear glass protective sensor window (replaces IR filter in camera head)	EK000624
IR cut filter (camera is shipped with this filter mounted) refer to Appendix D	EK000625

All cable lengths are 0.5m unless stated otherwise.

Please also refer to the VC website [www.vision-components.com](http://www.vision-components.com) for an up to date list of accessories.

## 7 Programming VCSBC40XX Cameras

The VCSBC40XX operating system includes some additional functions, mainly for the control of the additional interfaces. Without direct VGA output some video control functions are not implemented for this camera.

This manual describes the differences between the standard VCRT 5 operating system functions and the special function library of the VCSBC40. For programming please also consult the [VCRT 5](#) and [VCLIB 2.0 and VCLIB 3.0 manuals](#) (see the list of references at the beginning of this manual).

### 7.1 Special Software requirements for the VCSBC40XX

The following table shows the minimum compatible setup options using the VCSBC40XX camera:

Code Composer Studio Version	VCRT PC Lib Version	VCLIB Version	VCRT Camera OS Version:
CCS 2.1 (C6000) or CCS 3.1 (C6000) <sup>9</sup>	VCRT 5.18	VCLIB 2.0 and 3.0	VCRT 5.22

Refer to the [SW Compatibility Overview](#), available in the Customer Download Area under [Customer Area](#) ▶ [VCRT & VCLIB PC Library Updates for VC20XX & VC40XX](#) for an overview of the latest compatible set up.

The VCRT PC lib Operation System PC library, the VCLIB Image Processing Library as well as the VCRT Camera Operation System can be downloaded from Support section of the Vision Components Website.

Software manuals are located in the “Registered User Area”. This download area can be accessed after registration and log in on the VC Website.

Software updates are available from the “Customer Area”. For access to the customer area please register your Vision Components development software for VC cameras with TI processor. Software registration can be done after logging in using the license key code shipped with each development bundle. For this please follow the “Register your Software” link under the “User Menu”.

---

<sup>9</sup>TPPT For using CCS3.1 insert “strip6x new.out” as first line under “build options -> final build steps”.

## 7.2 Ethernet Communication

The default camera IP address is 192.168.0.65 – as with all Ethernet cameras from VC.

The IP address can be changed to a different loading a #IP file into camera memory.

(see [Support->Customer Area->Getting Started VC20XX ... Programming Tutorial Basic](#) for details).

The camera supports DHCP server IP address allocation. In order to use DHCP allocation, the entry “DHCP” needs to be added to the #IP file as shown:

```
DHCP
IP: 192.168.0.81
MSK: 255.255.255.0
GTW: 192.168.0.1
```

The camera uses the specified IP address if DHCP allocation is not successful. If no IP address is specified in the #IP file, the camera falls back to the default address:

```
192.168.0.65
```



Please use DHCP server functions to determine the IP address allocated to the camera. Most server show a list of mac addresses and corresponding IP addresses or allow to allocate fixed IP addresses to a certain mac address. Determine the mac address of the camera using the shell command “type #ID” to prior to using DHCP IP address allocation!

## 7.3 Using FTP with the VCSBC40XX

With VCRT 5.18 and higher, the use of any standard ftp client is now possible. The following server commands have been added: SYSTEM,PWD,CWD,LIST,DEL

Programs have to be uploaded as “out” files into the camera flash memory. Ascii files like the autoexec or #IP files can be uploaded as “\*.txt” files – the conversion into \*.msf” files is not required.

## 7.4 Preventing Autoexec Execution / IP number reset

Preventing the execution of an Autoexec file by attempting a connection with the camera (as described in the programming tutorial) does not work, due to the increased processor speed. Resetting the camera using a keypad as with the VC20XX cameras is also not possible.

There are three ways of preventing the Autoexec execution and resetting the IP address:

### Option 1:

1. Upload an empty autoexec/ #IP file via FTP into the camera memory, overwriting the existing file(s).
2. Hardware reset of camera.

**Option 2:** CPU reset with help of an Emulator.

**Option 3:** Resetting the camera with help of the “VCnet Recovery Tool” as described in the following section.

### 7.4.1 Resetting the Camera with help of the VCnet Recovery Tool

A new tool – the “Vcnet Recovery Tool” is provided for resetting the IP address of the VCSBC40XX and VC40XX cameras. Vcnet Recovery is supported from camera OS VCRT 5.21.

In order to use the VCnet Recovery tool, follow the steps below:

1. Download and install the “**Java(TM) 2 Runtime Environment, Standard Edition 1.4.XX**” on your PC (Download from [www.sun.com](http://www.sun.com) - > Downloads - > J2SE v 1.4.2\_11 JRE ).
2. Download **VCnet Recovery Tool for VC40XX and VCSBC40XX** from [www.vision-comp.com](http://www.vision-comp.com) -> Support -> Customer Area ▶ *Software Utilities*
3. Unpack the “vcnet1.2.zip” folder a directory on your harddrive (for instance C:\ti\Util...).
4. Open the Dos command line window and chang to the directory containing “vcnet.jar”.
5. Execute the following command from the DOS Window "java -jar vcnet.jar -snr 5912345" , by specifying the camera serial number as shown. This command sends vcp packets via UDP broadcast for the next 15 seconds. Sending this command resets the corresponding camera to the default IP address and bypasses Autoexec execution. Further options below.
6. Boot the corresponding camera (power on) during the next 15 seconds. During start up the camera listens 0.5 seconds for cvp packets send with vcnet.jar.
7. If a valid vcp packet is received from camera an answer packet is sent (see example below). The camera continues booting in standard configuration:

Default IP address:	192.168.0.65
Mask:	255.255.255.0
Gateway:	none

**An autoexec in flash memory is not executed.**

#### Example of resetting a VCSBC40XX, S/N 0100151:

```
C:\Programme\VCnet>java -jar vcnet.jar -snr 0100151
VCnet Recovering Tool Version 1.2 - Copyright Vision Components 2005

Recovering Serial Number = 100151

Listening on port 67 for incoming packets!

Packet 2 from: /0.0.0.0

===Data as Text===

model: VC4018E
S/N: 0100151
DC: 06/10/05 09:23:06
MAC: 00-06-1F-01-87-37
IP: 192.168.0.81
MSK: 255.255.255.0
GTW: 192.168.0.1
....
```

## 7.5 Special VCRT functions for programming VCSBC40XX cameras

This sections explains the specifics of programming VC4018 cameras.

### 7.5.1 Trigger Functions

Apart form the inverse TTL logic (see section 5.2.2) and the different status register shown below, the trigger works like with the VC20XX cameras.

Please refer to the VCRT5.pdf manual – available form the Registered User Area of the VC website. The differences in programming the trigger interface are highlighted below.

Querying the status of the trigger Input as shown in the demo program “trigin.c” with “TrigInp = (int)((volatile int \*)VIRTX\_STAT) & 0x2000)” does not work with the VC4018.

To query the trigger input, use the following command instead:

```
...
if (GET_TRIG_SIGNAL() & 1)
    print("external trigger = 1\n");
else
    print("external trigger = 0\n");
...
```

The trigger output can be set to exposure controlled mode – for instance to control a light source. With TRIGOUT\_EXP() combined with TRIGOUT\_POS(), the trigger output is high during exposure. TRIGOUT\_EXP() combined with TRIGOUT\_NEG(), the trigger output is low during exposure.

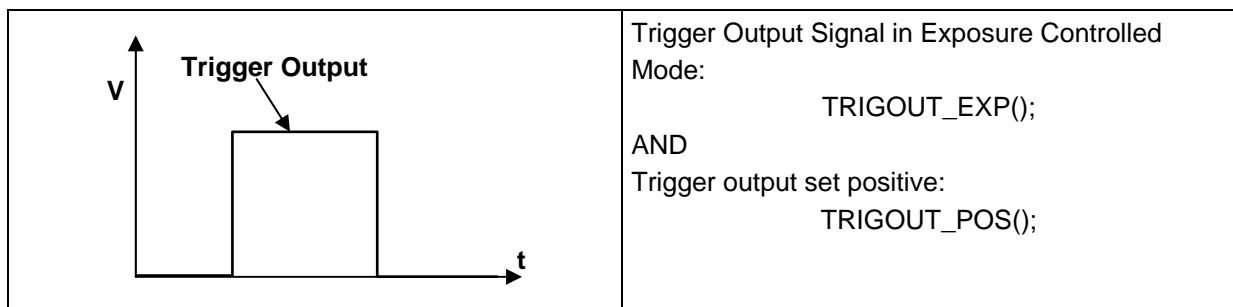

## 7.5.2 Controlling the Illumination Interface J1

The Illumination Interface has proven useful with the VCSBC50 camera and has therefore been also integrated into the VCSBC40XX. Due to the different processor, the use of this interface is slightly different.

There are two different modes for switching the Illumination Enable Signal (Pin 3, J1).

- User Mode and
- Exposure Mode

In Exposure mode (default) the “illumination enable” signal on socket J 1 is coupled to the trigger output on socket J 2, allowing to switch a light source during image acquisition with either contact. In user mode, the Illumination enable signal can be switched independent from the image acquisition.

The corresponding commands are:

```
ILLU_USR();  
ILLU_EXP();
```

The functions ILLU\_POS() and ILLU\_NEG() can be used to inverse the Illumination voltage. Calling the function “ILLU\_USR()” and then “ILLU\_NEG” sets “Illumination Enable” high, independent from the image acquisition.

## 7.5.3 Controlling the TTL IOs on socket J2

Setting and reading the 4LVTTTL inputs and outputs is done with help of the hardware registers.

The following macros are available for easier operation (see “vcrt.h”):

- Setting the 4 outputs is done with help of a 4 bit value:

```
#define TTL_OUT(x) *((volatile int *)FA40_LED) = x          /* SBC4018 TTL output */
```

- For quering the TTL inputs use the following function:

```
#define GET_TTL_IN() (*((volatile int *)FA40_TTL) & 0x0F) /* SBC4018 TTL input */
```

## Appendix A: Block diagram VCSBC40XX Smart Camera

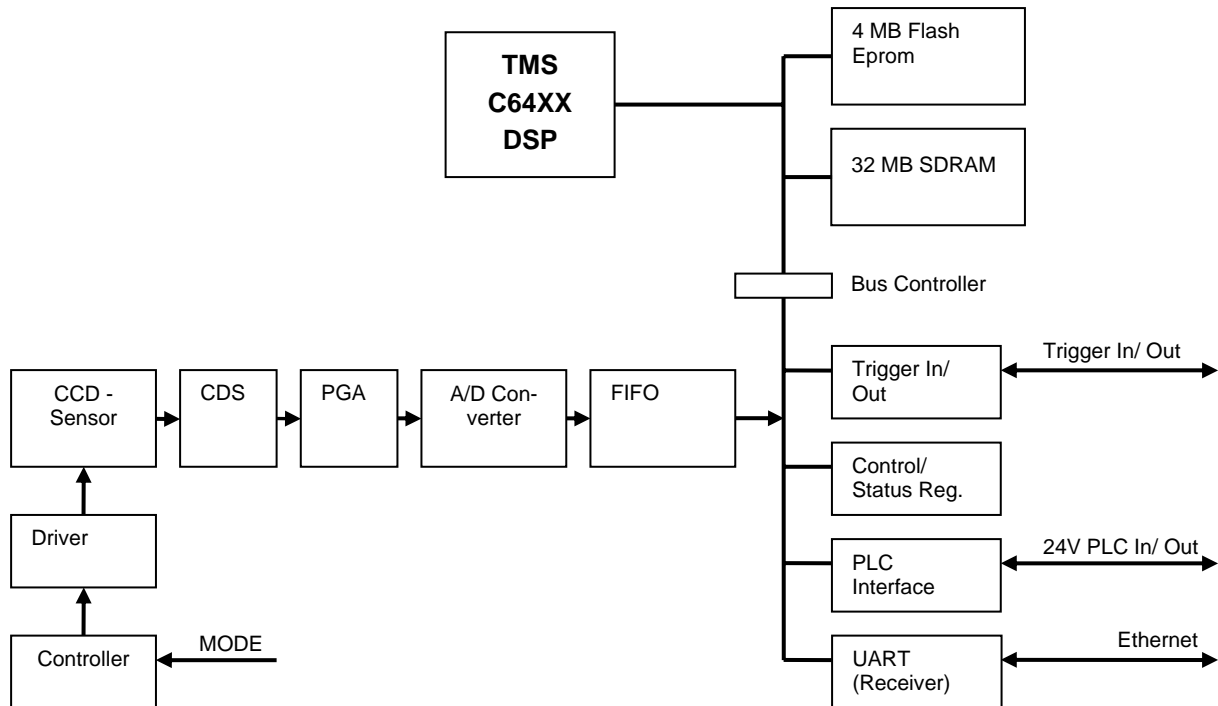

## Appendix B: New VCRT Functions VCSBC40XX Smart Camera

New VCRT functions (see section 7 and vcrt.h):

#define SET_BOOST()	set_ctrl_reg(BOOST)	/* boost / SBC4018*/
#define RES_BOOST()	res_ctrl_reg(BOOST)	/* boost / SBC4018*/
#define ILLU_POS()	res_ctrl_reg(ILLU_pol)	/* illumination polarity*/
#define ILLU_NEG()	set_ctrl_reg(ILLU_pol)	/* illumination polarity*/
#define ILLU_USR()	set_ctrl_reg(ILLU_usr)	/* illumination user*/
#define ILLU_EXP()	res_ctrl_reg(ILLU_usr)	/* illumination normal*/
#define GET_HW_STATUS()	((*(volatile int *)FA40_STATUS) & 0x3F)	/* CPLD relase number*/
#define GET_TRIG_SIGNAL()	((*(volatile int *)FA40_STATUS) >> 7) & 1)	/* trigger signal*/
#define UART_INSTALLED()	((*(volatile int *)FA40_STATUS) >> 6) & 1)	/* 1 if UART installed*/
#define TTL_OUT(x)	*((volatile int *)FA40_LED) = x	/* SBC4018 TTL output*/
#define GET_TTL_IN()	((*(volatile int *)FA40_TTL) & 0x0F)	/* SBC4018 TTL input*/

### Appendix C: Overall Dimensions VCSCB40XX

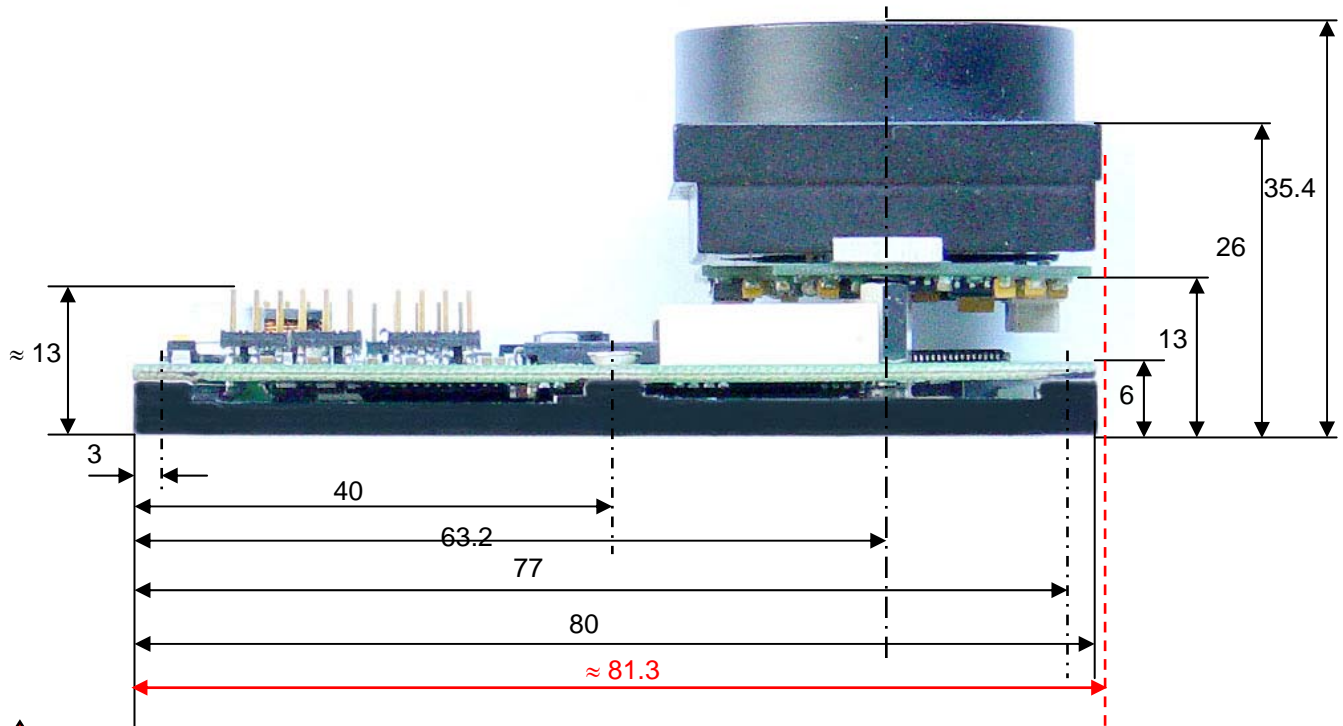

**Note:** the sensor head protrudes the circuit board slightly when mounted as shown!  
**Tolerances:** All vertical dimensions: +/- 0.5mm. All horizontal dimensions: +/- 0.1mm.

### Appendix D: Drawing Circuit Board VCSCB40XX

The red dot ● marks the Pin 1 position of each connector.

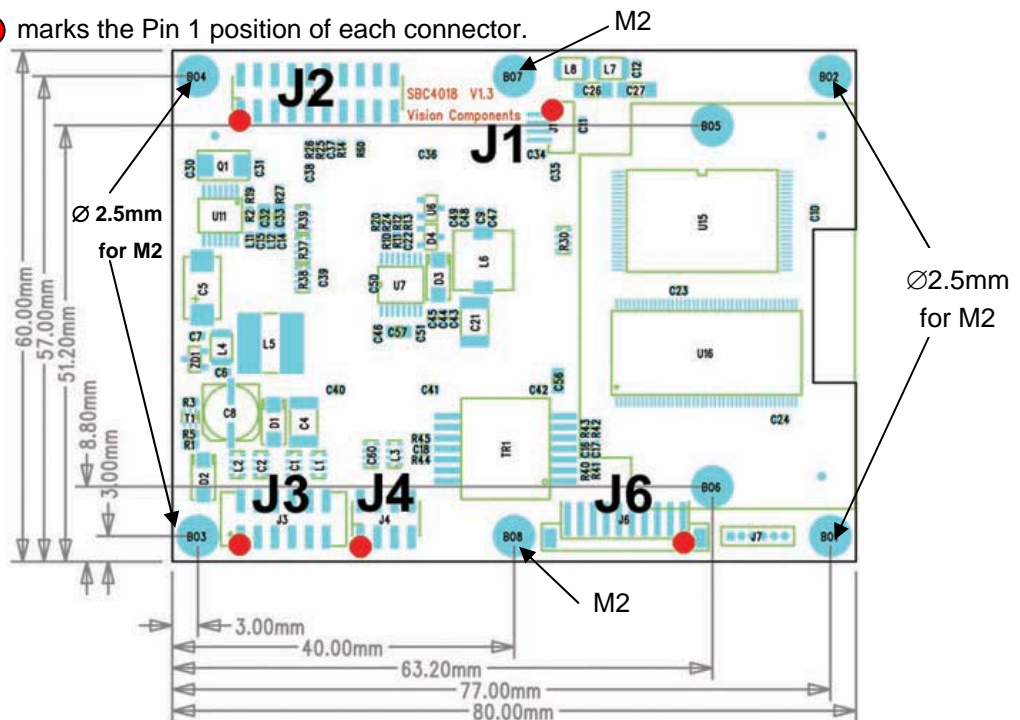

**Tolerances:** All circuit board dimensions: +/- 0.1mm

## Appendix E: Drawing Camera Head VCSCBC40XX

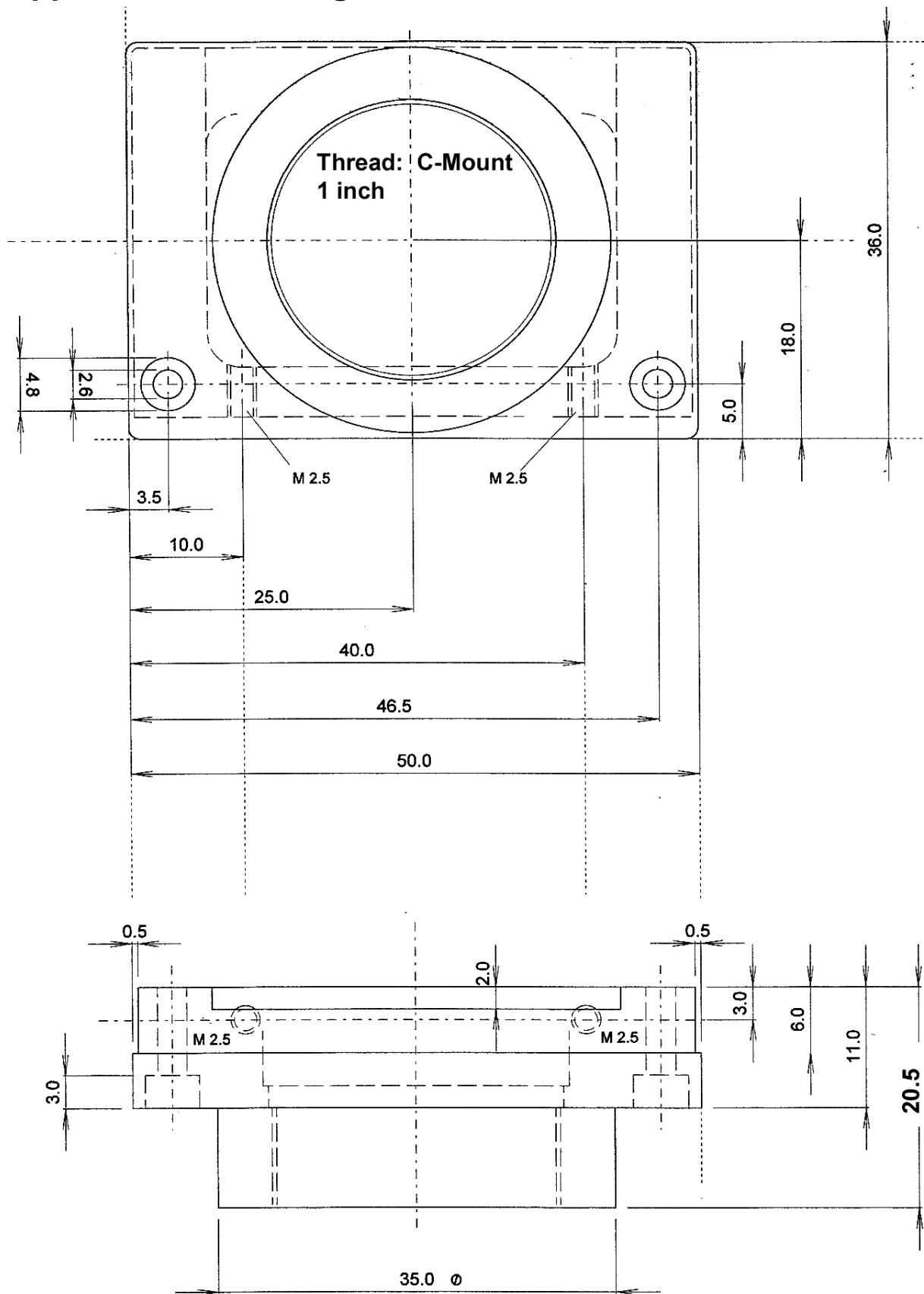

**Tolerances:** All dimensions: +/- 0.1mm

## Appendix F: Spectral Transmission of IR Filter

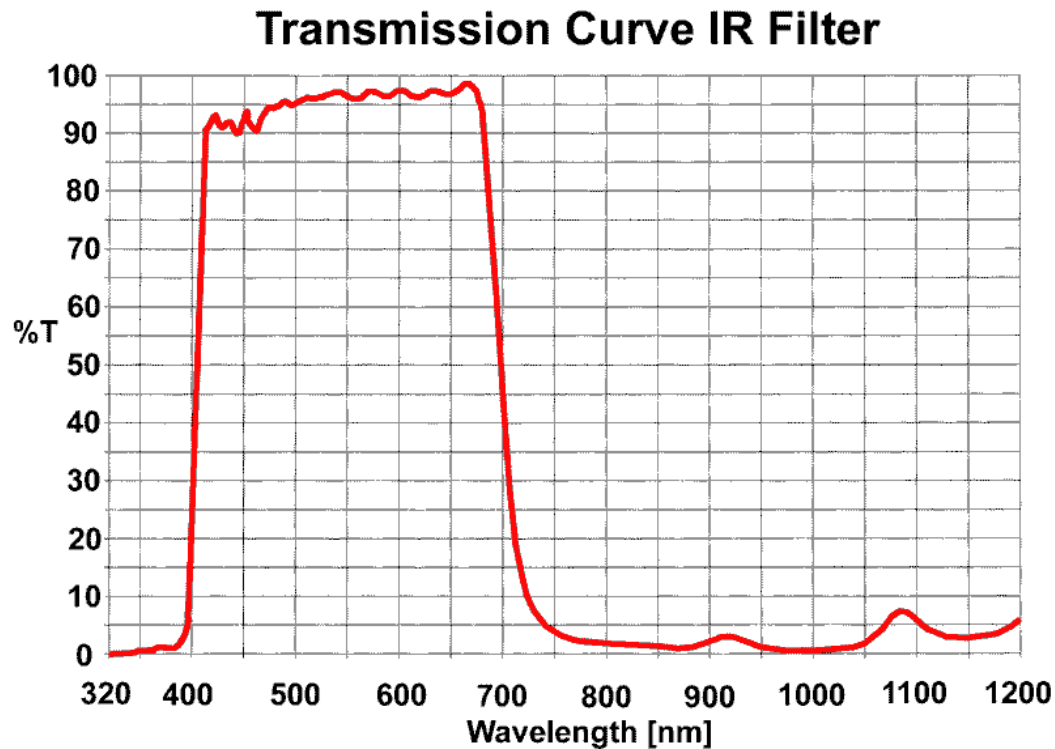

**Note:**

This IR cut filter is incorporated in every VCSBC40XX camera with C- mount lens holder. The IR filter can be removed if required. In this case, special care must be taken not to damage the CCD sensor.



If the camera is used without IR filter it is important to replace it by a clear glass filter of the same size. The C-mount flange distance from the CCD is accurately adjusted for the use of the IR filter – removing the filter decreases the length of the optical path and it may become impossible to focus some lenses to a larger working distance.

If the IR filter is not to be used, please order your camera with a clear glass filter or contact Vision Components for obtaining a glass filter.

The order numbers for the clear glass filter is: EK000624

The order number for the IR cut filter (standard) is: EK000625

# It's no trick... it's a vision system

Visit the Vision Components site [www.vision-components.com](http://www.vision-components.com) for further information and documentation and software downloads:

Web Site Menu Links	Content
<b>Home</b>	Latest News from VC
<b>Our Company</b>	VC Company Information
<b>Contact Us</b>	Distributor list / Enquiry forms
<b>News</b>	More News form VC
<b>Products</b>  <b>VC Hardware</b>  VCXX Camera Series VC20XX, VC4XXX Smart Cameras VCSBC Board Cameras VCM Camera Sensors  <b>VC Software</b>  VCRT Operating System VCLIB Image Processing Library Vision Components' Special Libraries  <b>3<sup>rd</sup> Party Software</b>	Product Overviews: including accessories listings with corresponding order numbers          M200 Data Matrix Code Reader VCOCR Text Recognition Color Lib Overview of 3 <sup>rd</sup> Party software available for VC Smart Cameras
<b>Support:</b>  <b>Support News</b>	Overview about latest features, manuals and SW updates
<b>Knowledge Base / FAQ</b>	Searchable HW and SW information database
<b>Download Area</b>  <b>Public Download Area</b> (free access) <b>Registered User DI Area</b> (registration required) <b>Customer Download Area</b> (user- and software registration required)	Download of all: <ul style="list-style-type: none"> <li>- Product brochures </li> <li>- Camera Manuals</li> <li>- Programming Manuals</li> <li>- Software updates</li> <li>- Demo Codes</li> <li>- Programming Tutorials</li> </ul>